

LOW VOLTAGE AC DRIVES

# ABB machinery drives

ACS380, 0.37 to 30 hp / 0.25 to 22 kW



---

**The ACS380 machinery drive is ideal for both machine builders looking to integrate a VFD without incurring significant cost and end users wanting to increase productivity without sacrificing performance. With pre-configured drive variants, adaptive programming and an icon-based user interface, this drive is simple to integrate into your system.**

---

# Table of contents

4	<b>The ACS380 machinery drives</b>
6	<b>Adaptability, reliability and high performance for machine building</b>
8	<b>ACS380 drives software with versatile features</b>
9	<b>Technical data</b>
10	<b>How to select and order a drive</b>
12	<b>Ratings, types and voltages</b>
13	<b>Dimensions</b>
14	<b>Control panel and configuration tools</b>
16	<b>Network connectivity and standard connections</b>
18	<b>I/O extensions and feedback module</b>
19	<b>EMC data and cable lengths</b>
20	<b>Cooling and sound level</b>
21	<b>Fuses and circuit protection</b>
22	<b>Braking resistors and technical data</b>
32	<b>Input amp ratings</b>
33	<b>Input reactors</b>
35	<b>dv/dt output filters</b>
36	<b>Need a motor? This is our offering.</b>
38	<b>Drive services and product lifecycle</b>

# The ACS380 machinery drives

## The perfect drive for precise performance

The ACS380 is an all-compatible machinery drive ideal for machine building thanks to its robust and compact design. All-compatible ABB drives share the same architecture and user interface for ease of use.

### Easy to adapt and configure to machines

With ACS380, commissioning is quick and easy thanks to the icon-based navigation on the integral control panel. Connecting to automation systems is easy thanks to preconfigured fieldbus protocols. On the hardware side, ease of use has been enhanced by having all the essential features built-in as standard. This reduces the need for additional hardware and simplifies drive selection.

### Precise performance for your application

The ACS380 machinery drive is a robust and compact drive ideal for machine building. It is ready-customized and comes in a power range from 1/3 to 30 Hp, and voltages from 200 to 240 V (one and three-phase) and 380 to 480 V (three-phase). ACS380 offers EMC and connectivity variants with built-in EMC filters and/or preconfigured fieldbus protocols for ease of integration and connectivity. This saves a lot of time and money for machine builders using large numbers of drives per year.

### Reliability and consistent high quality

The ACS380 drives have improved durability and reliability in harsh conditions, including coated circuit boards and enclosure IP20 as standard. All drives are tested during production at maximum temperatures with nominal loads. Tests cover both performance and all protective functions. The drives are designed for an ambient temperature of up to 50°C without derating. The drives have in their class a unique 3-phase measurement that gives very reliable earth fault protection. Also, the foil coated control panel offers a good protection against dust and gases and the galvanically isolated fieldbus gives good noise immunity.

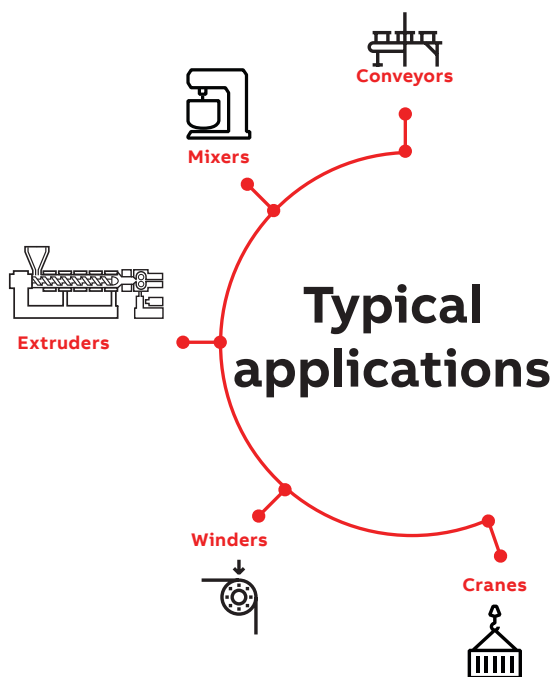



# Adaptability, reliability and high performance for machine building

The ACS380 machinery drives are part of ABB's all-compatible drives portfolio. The drives give you consistent performance throughout their whole life cycle. They also offer a wider range of standard and optional features for optimal machine building.



## Ease of use built-in

ACS380 has as standard control panel with clear display. The control panel's icon-based menu helps you set up the drive quickly and effectively without needing to study manuals. If there is need for an alphanumeric, multilingual graphical user panel, also that is available.

Name	Value	Unit	Limit	Min	Max	Default
1. Actual speed						
2. Speed reference						
3. Motor speed						
4. Motor speed fault						
5. Stop time						
6. Control not active warning						
7. Reference limit						
8. Reference limit						
9. Reference limit						
10. Reference limit						
11. Reference limit						
12. Reference limit						
13. Reference limit						
14. Reference limit						
15. Reference limit						
16. Reference limit						
17. Reference limit						
18. Reference limit						
19. Reference limit						
20. Reference limit						
21. Reference limit						
22. Speed reference ramp						
23. Speed reference ramp						
24. Speed reference ramp						
25. Speed reference ramp						
26. Speed reference ramp						
27. Speed reference ramp						
28. Frequency reference ramp						
29. Limit						
30. Fault handling						

## All-compatible user interface making your life easier

ACS380 is part of ABB all-compatible drives portfolio. Other product in this portfolio are ACS480, ACS580 and ACS880 drives. All these drives have the same, easy to use PC tools and similar intuitive multilingual user interface as well as parameter structure, making using and learning them fast and easy.

## Simple to select and install

Built-in features such as an EMC filter, adaptive programming, integrated safety (STO), brake chopper, a Modbus RTU fieldbus interface and safe torque off functionality simplify drive selection, installation and use. DriveSize helps to select the optimal drive and motor for the application.



## Easy setup and integration to automation

ACS380 can be easily set-up by using the control panel or easy to use PC tools. Settings can also be copied to several drives by using either assistant control panel or PC tools. Also download the settings to an unpowered drive is possible by using the cold configuration tool. Preconfigured fieldbus protocols enable connectivity with all major industrial automation networks with minimized effort and complexity.





### Designed for maximum reliability

Design features like coated control boards, minimized air flow through the control board section, reliable earth fault protection by 3-phase current measurement and design for 50°C ambient temperature make ACS380 a safe choice for customers expecting high reliability. This is topped up by full load test that is done to every single drive during the production.



### Drive based programmability

ACS380 has built-in as standard possibility for adaptive programming that enables customizing the drive software by using either sequential or block programming. This can in some cases even eliminate the need of a separate PLC.



### UL Type 1 enclosure kits

Enhance installation flexibility by allowing the drive to be wall-mounted outside of an enclosure or to provide finger-safe protection inside an enclosure.



### Same startup and maintenance tools as for other ABB automation products

ACS380 is using the same tools as other ABB all-compatible drives. Drive composer PC tool for startup, configuration, monitoring and process tuning. Automation Builder for automation engineering and Drive Manager for single point of commissioning.

# ACS380 drives software with versatile features

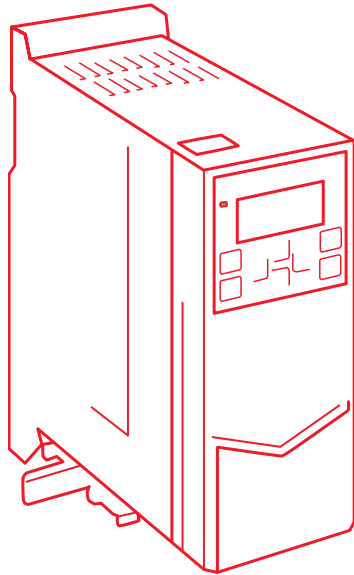

**Exceptional motor control performance.** Whether the requirement is high starting torque, accurate speed control, stable torque or tolerance for sudden load variations, ACS380 can do it with or without encoder feedback. ACS380 can be used even in simple positioning applications when using external motion controller.

**One drive for different motor types.** ACS380 supports perfectly both induction and permanent magnet motors.

**Silent motor operation.** Noise can be further reduced by the energy optimizer or by increasing the drive switching frequency.

**"Mini PLC" inside the drive.** Scale up and customize the drive to your application's requirements with adaptive programming.

**Easy integration to automation.** Preconfigured fieldbus protocols enable connectivity with all major industrial automation networks with minimized effort and complexity.

**Built-in support for limit switches**

**Integrated mechanical brake control**

**Additional machinery features like fast stop functions and parabolic speed reference**

**Analyze and optimize the process** with the load profile log, which shows you how the drive has been used.

# Technical data

Mains connection						
Voltage and power range	1-phase, 200 to 240 V, +10%/-15% 1/3 to 3 Hp 3-phase, 200 to 240 V, +10%/-15% 1/2 to 15 Hp 3-phase, 380 to 480 V, +10%/-15% 1/2 to 30 Hp					
Frequency	50/60 Hz ± 5%					
Common DC connection						
DC voltage level	-1 & 2 types 270 to 325 V ±10% -4 types 485 to 620 V ±10%					
Charging circuit	Internal charging circuit					
Motor connection						
Voltage	0 to $U_N$ , 3-phase					
Frequency	0 to 599 Hz					
Motor control	Scalar control Vector control					
Switching frequency	1 to 12 kHz, default 4 kHz					
Dynamic braking	Flux braking (moderate or full) Resistor braking (optional)					
Motor control performance						
Speed control performance, open loop						
Static accuracy	20% of motor rated slip					
Dynamic accuracy	1% with 100% torque step					
Speed control performance, closed loop						
Static accuracy	0.1% of motor rated speed					
Dynamic accuracy	<1% with 100% torque step					
Torque control performance						
Torque step rise time	< 10 ms, rated torque step					
Non-linearity	±5% with rated torque					
Braking power connection						
Brake chopper	Built-in brake chopper as standard					
Brake resistor	External resistor connected to drive					
Free space requirements						
Frame size	Free space requirements					
	Above		Below		On the sides <sup>1)</sup>	
	in	mm	in	mm	in	mm
R0-R4	3	75	3	75	0	0

<sup>1)</sup> Drives can be mounted side by side with no clearance. If side-mounted options will be used, leave .8 inches (20 mm) of space to the right of the drive.

Functional safety	
Built-in safety features	Safe torque off (STO) acc. to EN/IEC61800-5-2: IEC61508 ed2: SIL 3, IEC 61511: SIL 3, IEC 62061: SIL CL 3, EN ISO 13849-1: PL e
Environmental limits	
Ambient temperature	
Transportation and storage	-40 to +70 °C (-40 to +158 °F)
Operation	-10 to +50 °C (14 to 122 °F), no frost with derating up to 60 °C (except R0, which has max temperature of 50 °C)
Cooling method	Air-cooled, dry clean air
Altitude	0 to 4000 m, (0 to 13000 ft) for 400 V units (see allowed power systems in HW manual) 0 to 2000 m, (0 to 6600 ft) for 200 V units derating above 1000 m (3300 ft)
Relative humidity	5 to 95%, no condensation allowed
Degree of protection	IP20 as standard
Contamination levels	No conductive dust allowed
Storage	IEC 60721-3-1, Class 1C2 (chemical gases) Class 1S2 (solid particles)
Transportation	IEC 60721-3-2, Class 2C2 (chemical gases) Class 2S2 (solid particles)
Operation	IEC 60721-3-3, Class 3C2 (chemical gases) Class 3S2 (solid particles)
Product compliance	
CE	
Low Voltage Directive 2006/95/EC, EN 61800-5-1: 2007	
Machinery Directive 2006/42/EC, EN 61800-5-2: 2007	
EMC Directive 2004/108/EC, EN 61800-3: 2004 + A1: 2012	
UL, cUL certification - file E211945	
TUV Certification for functional safety	
Quality assurance system ISO 9001	
Environmental system ISO 14001	
Waste electrical and electronic equipment directive (WEEE) 2002/96/EC	
RoHS directive 2011/65/EU	
EAC	



# Ordering information

The type designation tells you the specifications and configuration of the drive.

The table shows the primary drive variants.

Sample type code 1: ACS380-040S-02A6-4 (I/O & Modbus variant, not possible to add options as pluscode)

Sample type code 2: ACS380-040C-02A6-4+K475+ L535 (Configured variant, possible to add options as pluscode)

Segment	A	B	C	D	E	F
ACS380	04	0	C	02A6	4	Option codes
Product series						
Types and construction						
Rating						
Voltage						
Option code						

## Basic codes

Segment	Option	Description
A	Construction	04 = Module, IP20
B	EMC filter	0 = C3 (480 V variant) or C4 (230 V Variant) - Standard for USA 2 = High filtering level for First environment (EN 61800-3, Class C2) - (Contact factory)
C	Connectivity	S = Standard variant (I/O and Modbus), C = Configured variant
D	Current rating	For example, 02A6 refers to a nominal output current of 2.6 A
E	Voltage rating	1 = 1-phase 230 V, 2 = 3-phase 230 V, 4 = 3-phase 480 V

## Option codes for configured variant (ACS380-04x)

Segment	Option	Code	Description		
F	Fieldbus	+K451	FDNA-01 DeviceNet protocol		
		+K454	FPBA-01 preconfigured Profibus-DP protocol		
		+K457	FCAN-01 preconfigured CANopen protocol		
		+K469	FECA-01 preconfigured EtherCAT protocol		
		+K470	FEPL-02 Ethernet POWERLINK protocol		
		+K475	FENA-21 preconfigured Profinet protocol (Ethernet/IP or Modbus/TCP built-in)		
		+K490*	FEIP-21 Preconfigured EtherNet/IP protocol		
		+K491*	FMBT-21 Preconfigured Modbus/TCP protocol		
		+K492*	FPNO-21 Preconfigured PROFINET IO protocol		
		+K495	BCAN-11 Preconfigured CANopen interface		
		I/O		+L511	BREL-01 External relay option (4x relay) (side option) <sup>1</sup>
				+L534	BAPO-01 External 24 V DC (side option)
				+L535	BTAC-02 HTL/TTL encoder interface + External 24 V DC (side option)
+L538	BMIO-01 I/O & Modbus extension module (front option)				
+L515	BIO-01 I/O extension module (front option, can be used together with fieldbus)				
Languages: The product package includes the User interface guide and Quick installation and start-up guide in English, French, German, Italian and Spanish. Printed manuals are available as an option in the languages shown. Other languages are available as downloads from ABB.com.		+R700	English		
		+R707	French		
		+R708	Spanish		
		+R714	Turkish		

\*Preconfigured K490, K491, K492 coming during 2020. In the meantime functionality can be done using K475.

# Ratings, types and voltages

<b><math>U_N = 200\text{ V}</math> (range 200 to 240 V). The power ratings are valid at nominal voltage 230 V (0.25 to 3.0 kW)</b>								
Light-overload use (230V)			Heavy-duty use (230V)			Maximum output current (230V)	Type designation	Frame size
$I_{Ld}$	$P_{Ld}$	$P_{Ld}$	$I_{Hd}$	$P_{Hd}$	$P_{Hd}$	$I_{max}$		
A	Hp	kW	A	Hp	kW	A		
2.3	0.5	0.37	1.8	0.33	0.25	3.2	ACS380-040x-02A4-1	R0
3.5	0.75	0.55	2.4	0.5	0.37	4.3	ACS380-040x-03A7-1	R0
4.6	1	0.75	3.7	0.75	0.55	6.7	ACS380-040x-04A8-1	R1
6.6	1.5	1.1	4.8	1	0.75	8.6	ACS380-040x-06A9-1	R1
7.4	2	1.5	6.9	1.5	1.1	12.4	ACS380-040x-07A8-1	R1
9.3	3	2.2	7.8	2	1.5	14.0	ACS380-040x-09A8-1	R2
11.6	3	3.0	9.8	3	2.2	17.6	ACS380-040x-12A2-1	R2

<b><math>U_N = 200\text{ V}</math> (range 200 to 240 V). The power ratings are valid at nominal voltage 230 V, 1/3 to 15 Hp (0.25 to 3.0 kW)</b>								
Light-overload use (230V)			Heavy-duty use (230V)			Maximum output current (230V)	Type designation	Frame size
$I_{Ld}$	$P_{Ld}$	$P_{Ld}$	$I_{Hd}$	$P_{Hd}$	$P_{Hd}$	$I_{max}$		
A	Hp	kW	A	Hp	kW	A		
2.3	0.5	0.4	1.8	0.33	0.25	3.2	ACS380-040x-02A4-2	R1
3.5	0.75	0.6	2.4	0.5	0.37	4.3	ACS380-040x-03A7-2	R1
4.6	1	0.8	3.7	0.75	0.55	6.7	ACS380-040x-04A8-2	R1
6.6	1.5	1.1	4.8	1	0.75	8.6	ACS380-040x-06A9-2	R1
7.5	2	1.5	6.9	1.5	1.1	12.4	ACS380-040x-07A8-2	R1
9.3	3	2.2	7.8	2	1.5	14	ACS380-040x-09A8-2	R1
11.6	3	3	9.8	3	2.2	17.6	ACS380-040x-12A2-2	R2
16.7	5	4	12.2	3	3	22	ACS380-040x-17A5-2	R3
24.2	7.5	5.5	17.5	5	3.7	31.5	ACS380-040x-25A0-2	R3
30.8	10	7.5	25	7.5	5.5	45	ACS380-040x-032A-2	R4
46.2	15	11	32	10	7.5	57.6	ACS380-040x-048A-2	R4
52.8	20	15	48	15	11	86.4	ACS380-040x-055A-2	R4

<b><math>U_N = 400\text{ V}</math> (range 380 to 480 V). The power ratings are valid at nominal voltage 480 V, 1/2 to 30 Hp (0.37 to 22 kW)</b>								
Light-overload use (480V)			Heavy-duty use (480V)			Maximum output current (480V)	Type designation	Frame size
$I_{Ld}$	$P_{Ld}$	$P_{Ld}$	$I_{Hd}$	$P_{Hd}$	$P_{Hd}$	$I_{max}$		
A	Hp	kW	A	Hp	kW	A		
1.6	0.75	0.55	1.1	0.50	0.37	2	ACS380-040x-01A8-4	R0
2.1	1	0.75	1.6	0.75	0.55	2.9	ACS380-040x-02A6-4	R1
3	1.5	1.1	2.1	1	0.75	3.8	ACS380-040x-03A3-4	R1
3.4	2	1.5	3	1.5	1.1	5.4	ACS380-040x-04A0-4	R1
4.8	2	2.2	3.4	2	1.5	6.1	ACS380-040x-05A6-4	R1
6	3	3	4	2	2.2	7.2	ACS380-040x-07A2-4	R1
7.6	5	4	4.8	3	3	8.6	ACS380-040x-09A4-4	R1
11	7.5	5.5	7.6	5	4	13.7	ACS380-040x-12A6-4	R2
14	10	7.5	11	7.5	5.5	19.8	ACS380-040x-17A0-4	R3
21	15	11	14	10	7.5	25.2	ACS380-040x-25A0-4	R3
27	20	15	21	15	11	37.8	ACS380-040x-032A-4	R4
34	25	19	27	20	15	48.6	ACS380-040x-038A-4	R4
40	30	22	34	25	18.5	61.2	ACS380-040x-045A-4	R4
42	30	22	40	30	22	72	ACS380-040x-050A-4	R4

$I_{MAX}$  Maximum output current. Available for 2 seconds at start, then as long as allowed by drive temperature.

$I_{Hd}$  Continuous current allowing 150%  $I_{Hd}$  for 1 minute every 10 minutes at 50 °C.

$P_{Hd}$  Typical motor power in heavy-duty use.

$I_{Ld}$  Continuous current allowing 110%  $I_{Ld}$  for 1 minute every 10 minutes at 50 °C.

$P_{Ld}$  Typical motor power in light-overload use.

The ratings apply at 50 °C ambient temperatures.

For derating at higher altitudes, temperatures or switching frequencies, see the user's HW manual, document code: 3AXD50000029274

# Dimensions

## ACS380 IP20

Frames	Height (H1)		Height (H2)		Height (H3)		Width (W)		Depth (D1)		Depth (D2)		(M1)		(M2)		Weight	
	in	mm	in	mm	in	mm	in	mm	in	mm	in	mm	in	mm	in	mm	lb	kg
R0	8.07	205	8.66	220	6.69	170	2.76	70	6.85	174	7.52	191	1.97	50	7.52	191	3.1	1.4
R1	8.07	205	8.66	220	6.69	170	2.76	70	6.85	174	7.52	191	1.97	50	7.52	191	3.5	1.6
R2	8.07	205	8.66	220	6.69	170	3.74	95	6.85	174	7.52	191	2.95	75	7.52	191	4.2	1.9
R3	8.07	205	8.66	220	6.69	170	6.65	169	6.85	174	7.52	191	5.83	148	7.52	191	6.4	2.9
R4	8.07	205	8.66	220	6.69	170	10.24	260	6.85	174	7.52	191	9.21	238	7.52	191	12.7	5.8

H1 Mounting surface height - back

H2 Height including grounding plate - back

H3 Enclosed height - front

W Width

D1 Depth

D2 Depth 2 (with deeper cover)

M1 Mounting hole distance 1

M2 Mounting hole distance 2

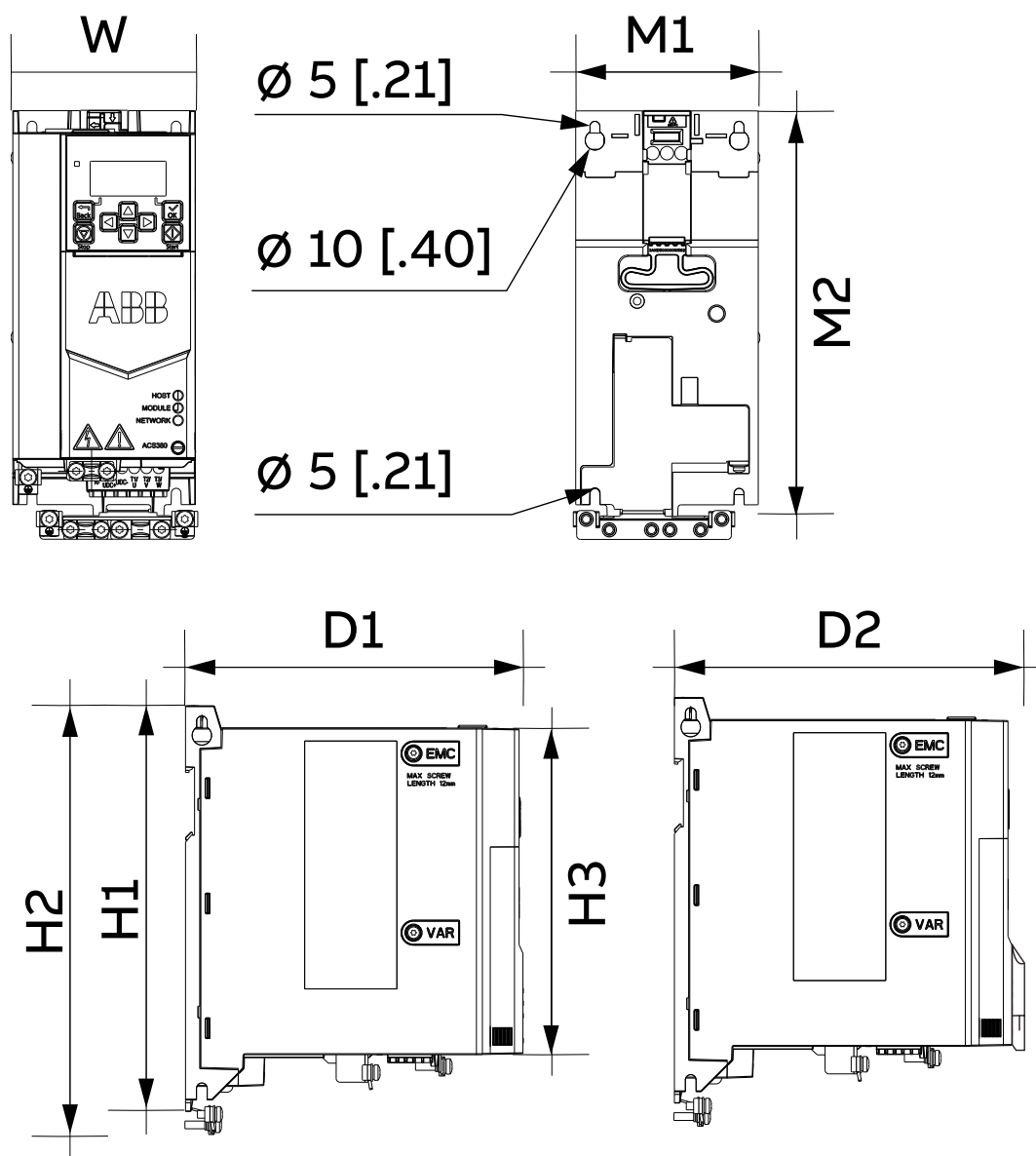

# Dimensions

## ACS380 drive with UL Type 1 kit

Frames	Height (H1)		Height (H2)		Height (H3)		Width (W <sup>1</sup> )		Depth (D)		(M1)		(M2)		(M3)	
	in	mm	in	mm	in	mm	in	mm	in	mm	in	mm	in	mm	in	mm
R0	8.1	205	11.2	285	9.7	247	2.8	70	7.5	191	1.97	50	7.52	191	1.26	32
R1	8.1	205	11.5	293	9.7	247	2.8	70	7.5	191	1.97	50	7.52	191	1.26	32
R2	8.1	205	11.5	293	9.7	247	3.7	95	7.5	191	2.95	75	7.52	191	1.26	32
R3	8.1	205	13.0	329	10.3	261	6.7	170	7.5	191	5.83	148	7.52	191	1.42	36
R4	8.1	205	15.3	391	12.3	312	10.2	260	7.7	196	9.21	234	7.52	191	1.5	38

H1 Height - back  
 H2 Height  
 H3 Height - front  
 W Width  
 D Depth  
 M1, M2, M3 Mounting hole distance

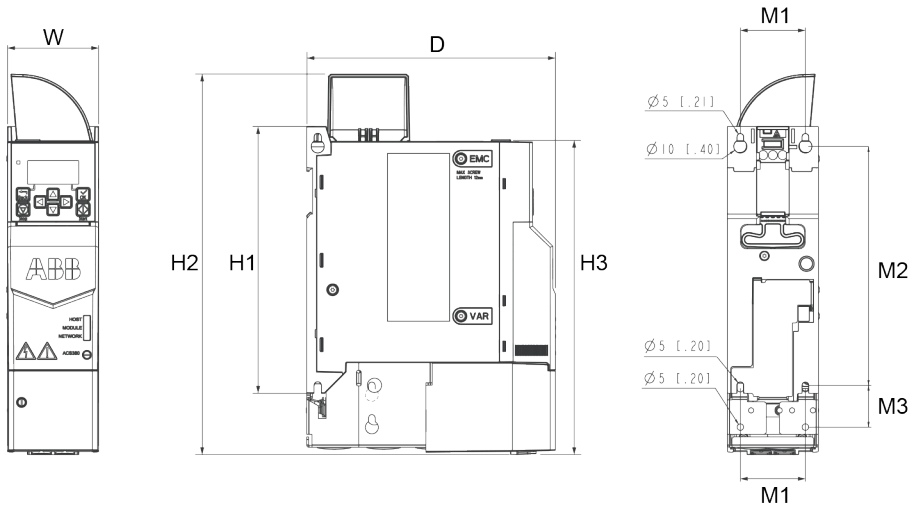

# Drive commissioning and adaptable use with your control panel

ACS380 has as standard an icon based control panel with clear display. If there is need for other type of panel or mounting the panel in the door of the enclosure, also that is possible.



## Control panel as standard

Almost anyone can set up and commission the machinery drive using available control panels. The ACS380 comes with the integrated icon based control panel as standard. You do not need to know any drive parameters as the control panel helps you to set up the essential settings quickly and get the drive into action. In addition, ACS380 supports the assistant control panel (AP-I, AP-S or AP-W).



## Assistant control panel, ACS-AP-I\*

The optional Assistant control has a graphical, multilingual display. There is no need to know any drive parameters, as the control panel helps you set up the essential settings quickly and get the drive into action without a hassle. Panel can be used with any products belonging to ABB all-compatible product portfolio.



## Bluetooth control panel, ACS-AP-W\*

The optional Bluetooth panel enables connection with the Drivetune mobile app. The app is available for free from Google Play and the Apple App store. Together with the Drivetune app and the Bluetooth panel, users can, for example, commission and monitor the drive remotely.



## Basic control panel, ACS-BP-S

If there is a need to install basic panel into cabinet door, ACS-BP-S is right choice. The icon based control panel supports users with basic operation, settings and fault tracking when nothing extra is needed.



## Control panel mounting platform, DPMP-01

This mounting platform is for flush mountings. The panel mounting platform does not include the control panel.



## Control panel mounting platform, DPMP-02

This mounting platform is for surface mounting. The panel mounting platform does not include the control panel.

\* Also compatible with other ABB all-compatible drives: ACS480, ACS580, and ACS880 drives.

Control panel options	
Type designation	Description
ACS-AP-I	Assistant control panel
ACS-AP-S	Assistant control panel
ACS-AP-W	Assistant control panel with bluetooth interface
ACS-BP-S	Basic control panel
DPMP-01	Control panel mounting platform (flush mounted)
DPMP-02	Control panel mounting platform (surface mounted)

# Tools for configuration, monitoring and process tuning

ACS380 has various tools simplifying the commissioning, operation and monitoring of the drive.



## Easy configuration for unpowered drives

With CCA-01 tool it is possible to configure drive parameters and even download a new software from PC to the unpowered ACS380. The power supply is taken from a PC USB port.

## Connect multiple drives to one control panel

The BSPL-01 panel bus adapter (RJ45 splitter) and the BPLG-01 termination plug allow the daisy chain connection of up to 32 ACS380 drives to one assistant control panel.



## PC tools

The Drive composer PC tool offers fast and harmonized setup, commissioning and monitoring. The free version of the tool provides startup and maintenance capabilities and gathers all drive information, such as parameter loggers, faults, and backups into a support diagnostics file. Drive composer pro provides additional features such as custom parameter windows, graphical control diagrams of the drive's configuration, and improved monitoring and diagnostics.

Using the BCBL-01 cable, the PC can be connected directly to the RJ-45 panel port on the top of the ACS380 drive.



When using the Assistant control panel, the Drive composer tool is connected to the drive using the mini USB connection on the panel.

Type designation	Description
BPLG-01	Panel bus termination plug
BSPL-01	Panel bus adapter (RJ45 Splitter)
BCBL-01	PC cable, USB to RJ45
CCA-01	Cold configurator adapter, packed kit
DCPT-01-KIT	Drive Composer Pro

# Flexible connectivity to automation networks

Fieldbus communication reduces wiring costs when compared with traditional hard wired input/output connections.

The ACS380 configured variant is compatible with a wide range of fieldbus protocols. Fieldbus modules come as preinstalled and preconfigured thus reducing commissioning time and allowing

drive commissioning from the PLC. The ACS380 standard variant comes with built-in Modbus RTU protocol.

**Support tools for integration with automation**  
Support for the fieldbuses is not always enough alone to get the full functionality and to make the integration easy. Due to this ABB also offers tools for seamless integration to automation systems of various manufacturers.

## Universal communication with ABB fieldbus adapters

The machinery drives support the following fieldbus protocols:

Option code	Fieldbus protocol	Adapter
+K451	DeviceNet®	FDNA-01
+K454	PROFIBUS DP, DPV0/DPV1	FPBA-01
+K457	CANopen®	FCAN-01
+K469	EtherCAT®	FECA-01
+K470	Ethernet POWERLINK®	FEPL-01
+K475	Two port EtherNet/IP™, Modbus TCP, PROFINET IO	FENA-21
+K490	Ethernet/IP, dual port	FEIP-21
+K491	Modbus/TCP, dual port	FMBT-21
+K492	PROFINET IO, dual port	FPNO-21
+K495	CANopen Interface	BCAN-01



Default I/O connections of standard variant

# Standard interface and extensions for ACS380 machinery drives

The ACS380 machinery drives offer two different standard interfaces: the standard variant (I/O and Modbus) and the configured variant with different interfaces. In addition, the drive has one option slot available that can be used for speed feedback, relay extensions or options which allow an external +24 V supply. For further information please see the ACS380 hardware and firmware manuals.

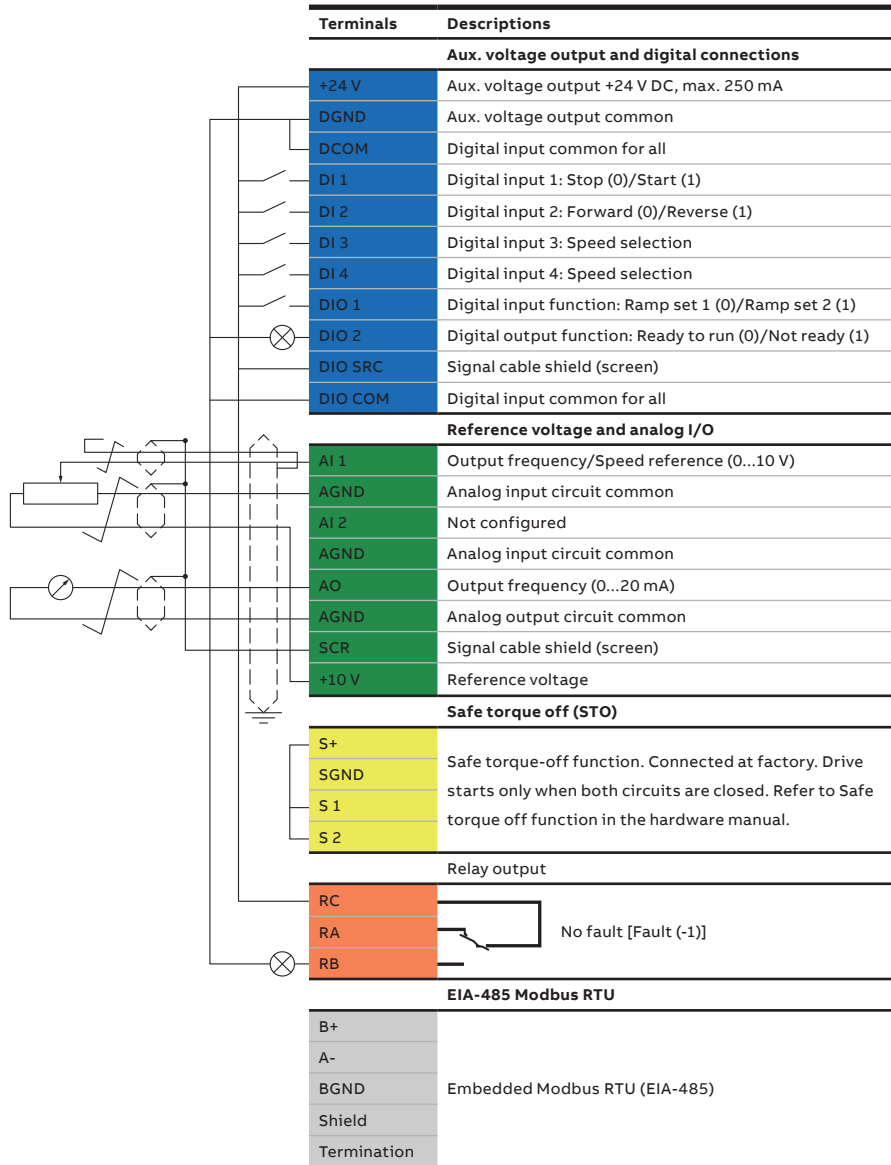
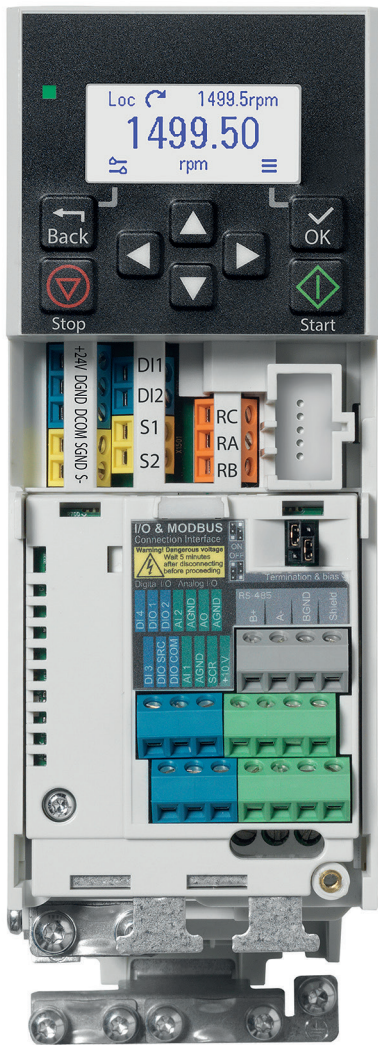

Default I/O connections of configured variant

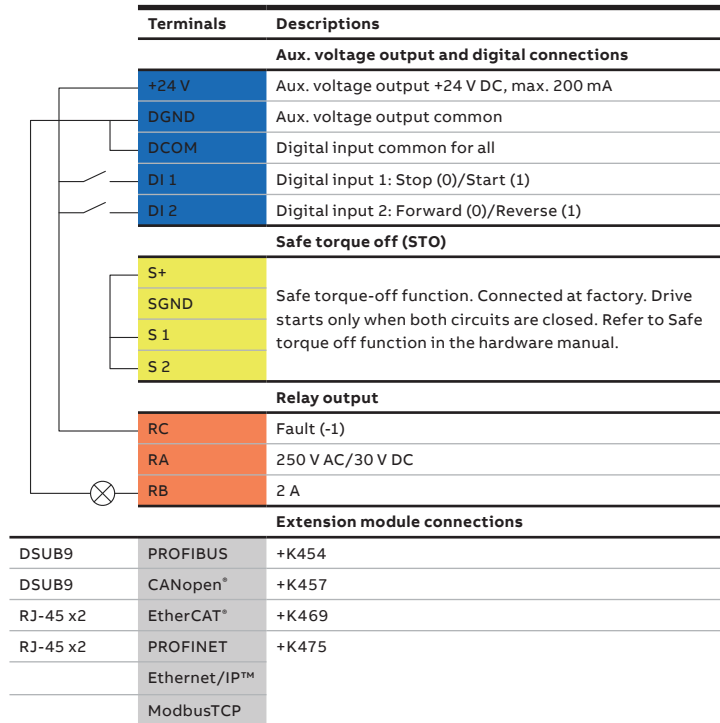

Configured variant I/O can be expanded using the BIO-01 module

# Input/output, extension and feedback modules for increased connectivity

Standard input and output of ACS380 machinery drives can be extended by using optional input/output extension modules. The modules are easily installed in the extension slots located on the side of the drive. It is also possible to use an optional speed feedback module that supports TTL and HTL pulse encoders.



Extension module options		
Option code	Description	Type designation
+L534	External 24 C DC	BAPO-01
+L511	External relay option (4xRO)	BREL-01
+L515	I/O extension*	BIO-01

\* For use with fieldbus modules only



Feedback interface module options		
Option code	Connections	Option
+L535	Encoder interface + External 24 V DC	BTAC-02

# EMC – electromagnetic compatibility

The ACS380 machinery drives are equipped with a built-in filter to reduce high frequency emissions. Drives with low EMC filters (C3 for 230 V and 480 V) are standard for the US and denoted by type codes ACS380-040X. Drives with high EMC filters (C2 for all voltages) are denoted by type codes ACS380-042X. Consult ABB for availability. C1 can be achieved with an external EMC filter.

## EMC standards

The EMC product standard (EN 61800-3) covers the specific EMC requirements stated for drives (tested with motor and cable) within the EU. EMC standards such as EN 55011 or EN 61000-6-3/4 are applicable to industrial and domestic equipment and systems including components inside the

drive. Drive units complying with the requirements of EN 61800-3 are compliant with comparable categories in EN 55011 and EN 61000-6-3/4, but not necessarily vice versa. EN 55011 and EN 61000-6-3/4 do not specify cable length or require a motor to be connected as a load. The emission limits are comparable to EMC standards according to the table below.

## Domestic environments versus public low voltage networks

The first environment includes domestic premises. It also includes establishments directly connected without an intermediate transformer to a low voltage power supply network that supplies the buildings used for domestic purposes. The second environment includes all establishments directly connected to public low voltage power supply networks.

### Comparison of EMC standards

EMC according to EN 61800-3 product standard	EN 61800-3 product standard	EN 55011, product family standard for industrial, scientific and medical (ISM) equipment	EN 61000-6-4, generic emission standard for industrial environments	EN 61000-6-3, generic emission standard for residential, commercial and light-industrial environment
1 <sup>st</sup> environment, unrestricted distribution	Category C1	Group 1, Class B	Not applicable	Applicable
1 <sup>st</sup> environment, restricted distribution	Category C2	Group 1, Class A	Applicable	Not applicable
2 <sup>nd</sup> environment, unrestricted distribution	Category C3	Group 2, Class A	Not applicable	Not applicable
2 <sup>nd</sup> environment, restricted distribution	Category C4	Not applicable	Not applicable	Not applicable

## Motor cable length

The drive is designed to operate with optimum performance with the following maximum motor cable lengths. The motor cable lengths may be extended with an output choke as shown in the table.

Frame size	Maximum motor cable length	
	m	ft
<b>Standard drive, without external options</b>		
R0	150	492
R1, R2	150	492
R3, R4	150	492
<b>With external output chokes</b>		
R0	60	195
R1-R3	250	820
R4	200	656

Note: In multimotor systems, the calculated sum of all motor cable lengths must not exceed the maximum motor cable length given in the table.

# Cooling and sound level

## Cooling

ACS380 drives are fitted with variable-speed cooling air fans. The cooling air must be free from corrosive materials and not exceed the maximum ambient temperature of 50°C (60°C with derating\*).

### Cooling air flow

1-phase  $U_N = 200...240$  V (200, 208, 220, 230, 240 V)

		Heat dissipation*				Max. sound level
		Air flow		Air flow		
		W	BTU/Hr	m <sup>3</sup> /h	ft <sup>3</sup> /min	
ACS380-040x-02A4-1	R0	52	178	-*	-*	<30
ACS380-040x-03A7-1	R0	66	226	-*	-*	<30
ACS380-040x-04A8-1	R1	84	287	57	33	63
ACS380-040x-06A9-1	R1	109	373	57	33	63
ACS380-040x-07A8-1	R1	120	408	57	33	63
ACS380-040x-09A8-1	R2	140	477	63	37	59
ACS380-040x-12A2-1	R2	170	579	63	37	59

### Cooling air flow

3-phase  $U_N = 380...480$  V (380, 400, 415, 440, 460, 480 V)

		Heat dissipation*				Max. sound level
		Air flow		Air flow		
		W	BTU/Hr	m <sup>3</sup> /h	ft <sup>3</sup> /min	
ACS380-040x-01A8-4	R0	46	156	-*	-*	<30
ACS380-040x-02A6-4	R1	60	205	57	33	63
ACS380-040x-03A3-4	R1	67	229	57	33	63
ACS380-040x-04A0-4	R1	75	256	57	33	63
ACS380-040x-05A6-4	R1	93	317	57	33	63
ACS380-040x-07A2-4	R1	112	383	57	33	63
ACS380-040x-09A4-4	R1	139	476	57	33	63
ACS380-040x-12A6-4	R2	183	624	63	37	59
ACS380-040x-17A0-4	R3	232	793	128	75	66
ACS380-040x-25A0-4	R3	346	1182	128	75	66
ACS380-040x-032A-4	R4	460	1570	216	127	69
ACS380-040x-038A-4	R4	561	1916	216	127	69
ACS380-040x-045A-4	R4	663	2263	216	127	69
ACS380-040x-050A-4	R4	663	2263	216	127	69

\*Frame size R0 with free convection cooling

### Cooling air flow

3-phase  $U_N = 200...240$  V (200, 208, 220, 230, 240 V)

		Heat dissipation*				Max. sound level
		Air flow		Air flow		
		W	BTU/Hr	m <sup>3</sup> /h	ft <sup>3</sup> /min	
ACS380-040x-02A4-2	R1	39	133	57	33	63
ACS380-040x-03A7-2	R1	46	157	57	33	63
ACS380-040x-04A8-2	R1	56	189	57	33	63
ACS380-040x-06A9-2	R1	63	213	57	33	63
ACS380-040x-07A8-2	R1	71	240	57	33	63
ACS380-040x-09A8-2	R1	84	302	57	33	63
ACS380-040x-12A2-2	R2	107	366	63	37	59
ACS380-040x-17A5-2	R3	138	472	128	75	66
ACS380-040x-25A0-2	R3	182	620	128	75	66
ACS380-040x-032A-2	R4	247	845	216	127	69
ACS380-040x-048A-2	R4	349	1191	216	127	69
ACS380-040x-055A-2	R4	465	1587	216	127	69

# Fuses and circuit protection

## Fuse and circuit breakers

ABB UL file E211945 Volume 15, Section 4 lists the ABB Type E manual motor protectors MS132 & S1-M3-25 & MS165 as an alternate to UL classified fuses as a means of branch circuit protection. This is in accordance with the National Electrical Code (NEC). When the correct ABB Type E manual motor protector is selected from the table and used for branch circuit protection the drive is suitable for use in a circuit capable of delivering not more than 65 kA RMS symmetrical amperes at the drive

maximum rated voltage. See the following combined micro drive table for the appropriate ratings.

Combinations of Type E MMP's and drives installed with UL Type 1 kits are NOT included in the listing. Drive & MMP combinations must be assembled in an enclosure conforming to minimum enclosure volume. Consult ABB document LVD-PNTN22U-EN for alternate UL fuse selections

Type Designation	Frame Size	IEC fuses		UL fuses	Manual motor protector		Min. Encl. Vol. (cu in) <sup>5</sup>
		Type gG (A)	Type gR (A)	UL class T (A)	Input Amps I <sub>N</sub> (A)	MMP Type E <sup>1,2</sup>	
<b>Selection table</b>							
<b>1-phase AC supply, 200 to 240V</b>							
ACS380-040x-02A4-1	R0	10	32	10	5.0	MS132-6.3 & S1-M3-25 <sup>3</sup>	1850
ACS380-040x-03A7-1	R0	10	32	10	7.8	MS132-10 & S1-M3-25 <sup>3</sup>	1850
ACS380-040x-04A8-1	R1	16	40	20	10.1	MS165-16	1850
ACS380-040x-06A9-1	R1	20	50	20	14.5	MS165-16	1850
ACS380-040x-07A8-1	R1	25	63	25	16.4	MS165-20	1850
ACS380-040x-09A8-1	R2	32	63	25	20.6	MS165-25	1850
ACS380-040x-12A2-1	R2	35	63	35	25.6	MS165-32	1850
<b>3-phase AC supply, 200 to 240V</b>							
ACS380-040x-02A4-2	R1	6	25	6	3.6	MS132-6.3 & S1-M3-25 <sup>3</sup>	1850
ACS380-040x-03A7-2	R1	10	32	10	5.6	MS132-10 & S1-M3-25 <sup>3</sup>	1850
ACS380-040x-04A8-2	R1	10	32	10	7.2	MS132-10 & S1-M3-25 <sup>3</sup>	1850
ACS380-040x-06A9-2	R1	16	40	20	10.4	MS165-16	1850
ACS380-040x-07A8-2	R1	16	40	20	11.7	MS165-16	1850
ACS380-040x-09A8-2	R1	16	40	20	14.7	MS165-20	1850
ACS380-040x-12A2-2	R2	25	50	25	18.3	MS165-25	1850
ACS380-040x-17A5-2	R3	32	63	35	24.6	MS165-32	1850
ACS380-040x-25A0-2	R3	50	80	40	35.1	MS165-42	1850
ACS380-040x-032A-2	R3	63	100	60	45.0	MS165-54	4577
ACS380-040x-048A-2	R4	100	160	100	57.6	MS165-80	4577
ACS380-040x-055A-2	R4	100	160	100	60.0	MS165-80	4577
<b>3-phase AC supply, 440 to 480V<sup>4</sup></b>							
ACS380-040x-01A8-4	R0	4	25	6	2.6	MS132-4.0 & S1-M3-25 <sup>3</sup>	1850
ACS380-040x-02A6-4	R1	6	25	6	3.4	MS132-6.3 & S1-M3-25 <sup>3</sup>	1850
ACS380-040x-03A3-4	R1	6	25	6	4.8	MS132-6.3 & S1-M3-25 <sup>3</sup>	1850
ACS380-040x-04A0-4	R1	10	32	10	5.4	MS132-10 & S1-M3-25 <sup>3</sup>	1850
ACS380-040x-05A6-4	R1	10	32	10	7.7	MS132-10 & S1-M3-25 <sup>3</sup>	1850
ACS380-040x-07A2-4	R1	16	40	20	9.6	MS165-16	1850
ACS380-040x-09A4-4	R1	16	40	20	12.2	MS165-16	1850
ACS380-040x-12A6-4	R2	25	50	25	17.6	MS165-20	1850
ACS380-040x-17A0-4	R3	32	63	35	22.4	MS165-32	1850
ACS380-040x-25A0-4	R3	50	80	50	33.6	MS165-42	1850
ACS380-040x-032A-4	R4	63	100	60	37.9	MS165-54	4577
ACS380-040x-038A-4	R4	80	125	80	44.7	MS165-65	4577
ACS380-040x-045A-4	R4	100	160	100	49.8	MS165-73	4577
ACS380-040x-050A-4	R4	100	160	100	50.4	MS165-80	4577

<sup>1</sup> All manual motor protectors listed are Type E self-protected up to 65 kA. See ABB publication 2CDC131060M0202 - Manual Motor Starters Guide for complete technical data on the ABB Type E manual motor protectors. In order for these manual motor protectors to be used for branch circuit protection, they must be UL listed Type E manual motor protectors, otherwise they can be used only as an At Motor Disconnect. "At Motor Disconnect" is a disconnect just ahead of the motor on the load side of the panel.

<sup>2</sup> Manual motor protectors may require adjusting the trip limit from the factory setting at or above the drive input Amps to avoid nuisance tripping. If the manual motor protector is set to the maximum current trip level and nuisance tripping is occurring, select the next size MMP. (MS132-10 is the highest size in the MS132 frame size to meet Type E at 65kA; next size up is MS165-16.)

<sup>3</sup> Requires use of the S1-M3-25 line side feeder terminal with the manual motor protector to meet Type E self-protection class.

<sup>4</sup> 480V/277V delta systems only. Short-circuit protective devices with slash voltage ratings (e.g. 480V/277 VAC) can be applied only in solidly grounded networks where the voltage from line-to-ground does not exceed the lower of the two ratings (e.g. 277 V AC), and the voltage from line-to-line does not exceed the higher of the two ratings (e.g. 480 V AC). The lower rating represents the device's interrupting capability per pole.

<sup>5</sup> For all drives, the enclosure must be sized to accommodate the specific thermal considerations of the application as well as provide free space for cooling. For UL compliance the minimum enclosure volume is specified in the UL listing when applied with the ABB Type E MMP shown in the table. ACS380 drives must be mounted in an enclosure when used with MMP's. The UL Type 1 kit does not meet the requirements of an enclosure for this purpose. See ACS380 Hardware Manual 3AXD50000029274 for free space requirements.

<sup>6</sup> Branch circuit short-circuit protection for group installation by circuit breakers: Suitable for motor group installation on a circuit that is capable of delivering no more than 65 kA RMS symmetrical amperes, 480 V max. Use a circuit breaker with an interrupting rating of no less than 65 kA RMS symmetrical amperes, 480 V max. This is a condensed table for reference only. Refer to the complete tables in the ACS380 Hardware Manual 3AXD50000029274, including sizing for group installations, before sizing and selecting components.

# Brake resistor sizing

## Brake chopper

The brake chopper is built-in as standard for the ACS380. It not only controls braking, but also supervises system status and detects failures such as brake resistor and resistor cable short-circuits, chopper short-circuit, and calculated resistor over-temperature.

## Control of the mechanical brake

Mechanical brake control is integrated into the ACS380 machinery drives. It uses state machine logic to control brake opening, closing, holding, wait and delay to integrate complex brake operation into the application.

## Brake resistor

The brake resistors are separately available for the ACS380. Resistors other than the standard option resistors may be used, provided that the specified resistance value is within the specified limits and that the heat dissipation capacity of the resistor is sufficient for the drive application (see hardware manual). No separate fuses in the brake circuit are required if the conditions for e.g., the mains cable is protected with fuses and no mains cable/fuse overrating takes place.

Internal brake chopper					
	Frame	$P_{BRcont}$ (Hp)	$R_{min}$ (ohm)	$R_{max}$ (ohm)	$P_{BRmax}$ (Hp)
<b>1-phase <math>U_N = 200...240</math> V (200, 208, 220, 230, 240 V)</b>					
ACS380-040x-02A4-1	R0	0.33	33	468	0.5
ACS380-040x-03A7-1	R0	0.5	33	316	0.74
ACS380-040x-04A8-1	R1	0.75	33	213	1.1
ACS380-040x-06A9-1	R1	1	33	145	1.5
ACS380-040x-07A8-1	R1	2	33	97	2.2
ACS380-040x-09A8-1	R2	2	33	70	3.0
ACS380-040x-12A2-1	R2	3	20	47	4.4
<b>1-phase <math>U_N = 200...240</math> V (200, 208, 220, 230, 240 V)</b>					
ACS380-04xx-02A4-2	R1	0.33	39	474	0.5
ACS380-04xx-03A7-2	R1	0.5	39	319	0.74
ACS380-04xx-04A8-2	R1	0.75	39	217	1.1
ACS380-04xx-06A9-2	R1	1	39	145	1.5
ACS380-04xx-07A8-2	R1	1.5	39	105	2.2
ACS380-04xx-09A8-2	R1	2	20	71	3
ACS380-04xx-12A2-2	R2	2	20	52	4.4
ACS380-04xx-17A5-2	R3	3	16	38	6
ACS380-04xx-25A0-2	R3	5	16	28	8
ACS380-04xx-032A-2	R4	7.5	3	20	11
ACS380-04xx-048A-2	R4	10	3	14	15
ACS380-04xx-055A-2	R4	15	3	10	22
<b>3-phase <math>U_N = 380...480</math> V (380, 400, 415, 440, 460, 480 V)</b>					
ACS380-040x-01A8-4	R0	0.5	99	933	.74
ACS380-040x-02A6-4	R1	0.75	99	628	1.1
ACS380-040x-03A3-4	R1	1	99	428	1.5
ACS380-040x-04A0-4	R1	1.5	99	285	2.2
ACS380-040x-05A6-4	R1	2	99	206	3
ACS380-040x-07A2-4	R1	2	53	139	4.4
ACS380-040x-09A4-4	R1	3	53	102	6
ACS380-040x-12A6-4	R2	5	32	76	8
ACS380-040x-17A0-4	R3	7.5	32	54	11
ACS380-040x-25A0-4	R3	10	23	39	15
ACS380-040x-032A-4	R4	15	6	29	22
ACS380-040x-038A-4	R4	20	6	24	30
ACS380-040x-045A-4	R4	25	6	20	37
ACS380-040x-050A-4	R4	30	6	20	44

# Braking resistors

## Dynamic Braking Using the Built-in Braking Chopper (Transistor)

All ACS380 drives include a built-in brake chopper for use with a braking resistor to perform dynamic braking. No separate option kits need to be selected, no additional panel space is required, no additional installation time is needed to assemble a brake chopper. No separate fuses in the brake circuit are required if the mains cable is protected with fuses and no mains cable/fuse overrating takes place.

Use the following tables to select the correct brake resistor for your application. Either compact CR type resistors (for smaller drives) or standard enclosed resistor packages are available. For more information regarding the selection of other braking resistors and the limits of the built-in brake chopper, see the ACS380 Hardware Manual 3AXD50000029274.

## Single phase 200-240V applications, stopping duty only Type CR Resistors (Available for the small HP drives as listed below)

Duty Cycle		3sec on/27sec off			10sec on/50sec off		
ACS380-040x-	HP	CR Part No.	Ohms	Watts	CR Part No.	Ohms	Watts
02A4-1	0.33	P14494-CR-02	200	100	P14494-CR-02	200	100
03A7-1	0.5	P14494-CR-04	100	100	P14494-CR-04	100	100
04A8-1	0.75	P14494-CR-04	100	100	P14494-CR-04	100	100
06A9-1	1	P14494-CR-04	100	100	P14494-CR-11	100	150
07A8-1	1.5	P14494-CR-06	50	100	P14494-CR-12	50	150
09A8-1	2	P14494-CR-06	50	100	P14494-CR-18	50	200
12A2-1	3	P14494-CR-26	40	300	P14494-CR-34	40	400
Duty Cycle		30sec on/180sec off			60sec on/180sec off		
ACS380-040x-	HP	CR Part No.	Ohms	Watts	CR Part No.	Ohms	Watts
02A4-1	0.33	P14494-CR-02	200	100	P14494-CR-02	200	100
03A7-1	0.5	P14494-CR-04	100	100	P14494-CR-11	100	150
04A8-1	0.75	P14494-CR-11	100	150	P14494-CR-16	100	200
06A9-1	1	P14494-CR-11	100	150	P14494-CR-22	100	300
07A8-1	1.5	P14494-CR-18	50	200	P14494-CR-32	50	400
09A8-1	2	P14494-CR-24	50	300	P14494-CR-41	45	500
12A2-1	3	P14494-CR-34	40	400			

Notes: To determine resistor type, dimensions and weights refer to Resistor Technical Data Tables

# Braking resistors

## Standard Enclosed Resistor Packages

Duty Cycle		3sec on/27sec off			10sec on/50sec off				
ACS380-040x-	HP	Enclosed Res Part No.		Ohms	Watts	Enclosed Res Part No.		Ohms	Watts
02A4-1	0.33	P14494-19	75	300	P14494-19	75	300		
03A7-1	0.5	P14494-19	75	300	P14494-19	75	300		
04A8-1	0.75	P14494-24	45	300	P14494-24	45	300		
06A9-1	1	P14494-24	45	300	P14494-24	45	300		
07A8-1	1.5	P14494-31	35	300	P14494-31	35	300		
09A8-1	2	P14494-31	35	300	P14494-31	35	300		
12A2-1	3	P14494-31	35	300	P14494-31	35	300		

Duty Cycle		30sec on/180sec off			60sec on/180sec off				
ACS380-040x-	HP	Enclosed Res Part No.		Ohms	Watts	Enclosed Res Part No.		Ohms	Watts
02A4-1	0.33	P14494-19	75	300	P14494-19	75	300		
03A7-1	0.5	P14494-19	75	300	P14494-19	75	300		
04A8-1	0.75	P14494-24	45	300	P14494-24	45	300		
06A9-1	1	P14494-24	45	300	P14494-24	45	300		
07A8-1	1.5	P14494-31	35	300	P14494-32	35	820		
09A8-1	2	P14494-31	35	300	P14494-32	35	820		
12A2-1	3	P14494-32	35	820	P14494-32	35	820		

Notes: To determine resistor type, dimensions and weights refer to Resistor Technical Data Tables

# Braking resistors

**Three phase 200-240 V applications, stopping duty only**  
**Type CR resistors (available for the small Hp drives as listed below)**

Duty Cycle		3sec on/27sec off			10sec on/50sec off		
ACS380-040x-	HP	Enclosed Res Part No.	Ohms	Watts	Enclosed Res Part No.	Ohms	Watts
02A4-2	0.33	P14494-CR-02	200	100	P14494-CR-02	200	100
03A7-2	0.5	P14494-CR-04	100	100	P14494-CR-04	100	100
04A8-2	0.75	P14494-CR-04	100	100	P14494-CR-04	100	100
06A9-2	1	P14494-CR-04	100	100	P14494-CR-11	100	150
07A8-2	1.5	P14494-CR-06	50	100	P14494-CR-12	50	150
09A8-2	2	P14494-CR-06	50	100	P14494-CR-18	50	200
12A2-2	3	P14494-CR-12	50	150	P14494-CR-24	50	300
17A5-2	3	P14494-CR-54	18	300	P14494-CR-54	18	300
25A0-2	5	P14494-CR-54	18	300	P14494-CR-56	18	500
032A-2	7.5	P14494-CR-55	18	400			

Duty Cycle		30sec on/180sec off			60sec on/180sec off		
ACS380-040x-	HP	Enclosed Res Part No.	Ohms	Watts	Enclosed Res Part No.	Ohms	Watts
02A4-2	0.33	P14494-CR-02	200	100	P14494-CR-02	200	100
03A7-2	0.5	P14494-CR-04	100	100	P14494-CR-11	100	150
04A8-2	0.75	P14494-CR-11	100	150	P14494-CR-16	100	200
06A9-2	1	P14494-CR-16	100	200	P14494-CR-22	100	300
07A8-2	1.5	P14494-CR-18	50	200	P14494-CR-32	50	400
09A8-2	2	P14494-CR-24	50	300	P14494-CR-41	45	500
12A2-2	3	P14494-CR-33	45	400			
17A5-2	3	P14494-CR-55	18	400			

Notes: To determine resistor type, dimensions and weights refer to Resistor Technical Data Tables

# Braking resistors

## Standard Enclosed Resistor Packages

Duty Cycle		3sec on/27sec off			10sec on/50sec off		
ACS380-040x-	HP	Enclosed Res			Enclosed Res		
		Part No.	Ohms	Watts	Part No.	Ohms	Watts
02A4-2	0.33	P14494-19	75	300	P14494-19	75	300
03A7-2	0.5	P14494-19	75	300	P14494-19	75	300
04A8-2	0.75	P14494-24	45	300	P14494-24	45	300
06A9-2	1	P14494-24	45	300	P14494-24	45	300
07A8-2	1.5	P14494-24	45	300	P14494-24	45	300
09A8-2	2	P14494-24	45	300	P14494-24	45	300
12A2-2	3	P14494-24	45	300	P14494-24	45	300
17A5-2	3	P14494-31	35	300	P14494-31	35	300
25A0-2	5	P14494-39	21	400	P14494-40	21	750
032A-2	7.5	ABB-48431-060	11	409	ABB-48431-061	11	704
048A-2	10	ABB-48431-061	11	704	ABB-48431-062	11	931
055A-2	15	P14494-56	10	720	P14494-57	10	1250

Duty Cycle		30sec on/180sec off			60sec on/180sec off		
ACS380-040x-	HP	Enclosed Res			Enclosed Res		
		Part No.	Ohms	Watts	Part No.	Ohms	Watts
02A4-2	0.33	P14494-19	75	300	P14494-19	75	300
03A7-2	0.5	P14494-19	75	300	P14494-19	75	300
04A8-2	0.75	P14494-24	45	300	P14494-24	45	300
06A9-2	1	P14494-24	45	300	P14494-24	45	300
07A8-2	1.5	P14494-24	45	300	P14494-25	45	800
09A8-2	2	P14494-24	45	300	P14494-25	45	800
12A2-2	3	P14494-25	45	800	P14494-25	45	800
17A5-2	3	P14494-32	35	820	P14494-32	35	820
25A0-2	5	P14494-40	21	750	P14494-41	21	1050
032A-2	7.5	ABB-48431-062	11	931	ABB-48431-064	11	1584
048A-2	10	ABB-48431-063	11	1213	ABB-48431-066	11	2475
055A-2	15	P14494-58	10	1800	P14494-59	10	3600

Notes: To determine resistor type, dimensions and weights refer to Resistor Technical Data Tables

# Braking resistors

## Single phase 380-480V applications, stopping duty only

### Type CR Resistors (Available for the small HP drives as listed below)

Duty Cycle		3sec on/27sec off			10sec on/50sec off		
ACS380-040x-	HP	CR Part No.	Ohms	Watts	CR Part No.	Ohms	Watts
01A8-4	0.5	P14494-CR-01	500	125	P14494-CR-01	500	125
02A6-4	0.75	P14494-CR-01	500	125	P14494-CR-01	500	125
03A3-4	1	P14494-CR-02	200	100	P14494-CR-02	200	100
04A0-4	1.5	P14494-CR-02	200	100	P14494-CR-09	200	150
05A6-4	2	P14494-CR-03	150	100	P14494-CR-15	150	200
07A2-4	2	P14494-CR-04	100	100	P14494-CR-16	100	200
09A4-4	3	P14494-CR-11	100	150	P14494-CR-22	100	300
12A6-4	5	P14494-CR-24	50	300	P14494-CR-40	50	500
17A0-4	7.5	P14494-CR-32	50	400			
25A0-4	10	P14494-CR-38	23	500			

Duty Cycle		30sec on/180sec off			60sec on/180sec off		
ACS380-040x-	HP	CR Part No.	Ohms	Watts	CR Part No.	Ohms	Watts
01A8-4	0.5	P14494-CR-01	500	125	P14494-CR-01	500	125
02A6-4	0.75	P14494-CR-01	500	125	P14494-CR-07	500	150
03A3-4	1	P14494-CR-09	200	150	P14494-CR-14	200	200
04A0-4	1.5	P14494-CR-14	200	200	P14494-CR-20	200	300
05A6-4	2	P14494-CR-21	150	300	P14494-CR-29	150	400
07A2-4	2	P14494-CR-22	100	300	P14494-CR-57	100	500
09A4-4	3	P14494-CR-30	100	400			

Notes: To determine resistor type, dimensions and weights refer to Resistor Technical Data Tables

# Braking resistors

## Standard Enclosed Resistor Packages

Duty Cycle		3sec on/27sec off			10sec on/50sec off		
ACS380-040x-	HP	Enclosed Res Part No.	Ohms	Watts	Enclosed Res Part No.	Ohms	Watts
01A8-4	0.5	P14494-11	250	300	P14494-11	250	300
02A6-4	0.75	P14494-11	250	300	P14494-11	250	300
03A3-4	1	P14494-11	250	300	P14494-11	250	300
04A0-4	1.5	P14494-13	200	300	P14494-13	200	300
05A6-4	2	P14494-15	150	300	P14494-15	150	300
07A2-4	2	P14494-19	75	300	P14494-19	75	300
09A4-4	3	P14494-19	75	300	P14494-19	75	300
12A6-4	5	P14494-24	45	300	P14494-25	45	800
17A0-4	7.5	P14494-25	45	800	P14494-25	45	800
25A0-4	10	P14494-32	35	820	P14494-33	35	1200
032A-4	15	ABB-41154	22	900	ABB-44471	22	1455
038A-4	20	ABB-41154	22	900	ABB-44472	22	1904
045A-4	25	ABB-48431-063	11	1213	ABB-48431-066	11	2475
050A-4	30	ABB-48431-064	11	1584	ABB-48431-066	11	2475

Duty Cycle		30sec on/180sec off			60sec on/180sec off		
ACS380-040x-	HP	Enclosed Res Part No.	Ohms	Watts	Enclosed Res Part No.	Ohms	Watts
01A8-4	0.5	P14494-11	250	300	P14494-11	250	300
02A6-4	0.75	P14494-11	250	300	P14494-11	250	300
03A3-4	1	P14494-11	250	300	P14494-11	250	300
04A0-4	1.5	P14494-13	200	300	P14494-14	200	600
05A6-4	2	P14494-15	150	300	P14494-16	150	600
07A2-4	2	P14494-19	75	300	P14494-20	75	600
09A4-4	3	P14494-20	75	600	P14494-21	75	1000
12A6-4	5	P14494-25	45	800	P14494-26	45	1260
17A0-4	7.5	P14494-26	45	1260	P14494-27	45	1920
25A0-4	10	P14494-33	35	1200	P14494-35	35	2500
032A-4	15	ABB-44472	22	1904	ABB-48431-008	22	3168
038A-4	20	ABB-48431-007	22	2426	ABB-48431-009	22	5632
045A-4	25	ABB-48431-067	11	3564	ABB-48431-069	11	6875
050A-4	30	ABB-48431-067	11	3564	ABB-48431-069	11	6875

Notes: To determine resistor type, dimensions and weights refer to Resistor Technical Data Tables

# Braking resistors

## Technical data

Part Number	Ohms	Watts	Enclosure	Dimensions WxDxH (in)	Weight (lb)
ABB-41154	22	900	GCE3	12W x 10D x 5H	13
ABB-44471	22	1455	GCE4	12W x 13D x 5H	16
ABB-44472	22	1904	GCE5	12W x 16D x 5H	18
ABB-48431-007	22	2426	GCE6	19W x 10D x 5H	20
ABB-48431-008	22	3168	GCE8	19W x 13D x 5H	25
ABB-48431-009	22	5632	GCE9	26.5W x 10D x 5H	23
ABB-48431-060	11	409	GCE1	12W x 5D x 5H	7
ABB-48431-061	11	704	GCE2	12W x 7D x 5H	10
ABB-48431-062	11	931	GCE3	12W x 10D x 5H	13
ABB-48431-063	11	1213	GCE3	12W x 10D x 5H	13
ABB-48431-064	11	1584	GCE4	12W x 13D x 5H	16
ABB-48431-066	11	2475	GCE6	19W x 10D x 5H	17
ABB-48431-067	11	3564	GCE6	19W x 10D x 5H	19
ABB-48431-069	11	6875	GCE12	26.5W x 13D x 5H	28
P14494-11	250	300	GCE1	12W x 5D x 5H	7
P14494-13	200	300	GCE1	12W x 5D x 5H	7
P14494-14	200	600	GCE2	12W x 7D x 5H	10
P14494-15	150	300	GCE1	12W x 5D x 5H	7
P14494-16	150	600	GCE2	12W x 7D x 5H	10
P14494-19	75	300	GCE1	12W x 5D x 5H	7
P14494-20	75	600	GCE2	12W x 7D x 5H	10
P14494-21	75	1000	GCE3	12W x 10D x 5H	13
P14494-24	45	300	GCE1	12W x 5D x 5H	7
P14494-25	45	800	GCE2	12W x 7D x 5H	10
P14494-26	45	1260	GCE3	12W x 10D x 5H	13
P14494-27	45	1920	GCE5	12W x 16D x 5H	18
P14494-31	35	300	GCE1	12W x 5D x 5H	7
P14494-32	35	820	GCE2	12W x 7D x 5H	10
P14494-33	35	1200	GCE3	12W x 10D x 5H	13
P14494-35	35	2500	GCE8	19W x 13D x 5H	24
P14494-39	21	400	GCE1	12W x 5D x 5H	7
P14494-40	21	750	GCE2	12W x 7D x 5H	10
P14494-41	21	1050	GCE3	12W x 10D x 5H	13
P14494-56	10	720	GCE2	12W x 7D x 5H	10
P14494-57	10	1250	GCE3	12W x 10D x 5H	13
P14494-58	10	1800	GCE5	12W x 16D x 5H	18
P14494-59	10	3600	GCE6	19W x 10D x 5H	19

# Braking resistors

## Technical data

Part Number	Ohms	Watts	Enclosure	Dimensions WxDxH (in)	Weight (lb)
P14494-CR-01	500	100	CR100	6W x 1.5D x 0.75H	1
P14494-CR-02	200	100	CR100	6W x 1.5D x 0.75H	1
P14494-CR-03	150	100	CR100	6W x 1.5D x 0.75H	1
P14494-CR-04	100	100	CR100	6W x 1.5D x 0.75H	1
P14494-CR-06	50	100	CR100	6W x 1.5D x 0.75H	1
P14494-CR-07	500	150	CR150	9W x 1.5D x 0.75H	1
P14494-CR-09	200	150	CR150	9W x 1.5D x 0.75H	1
P14494-CR-11	100	150	CR150	9W x 1.5D x 0.75H	1
P14494-CR-12	50	150	CR150	9W x 1.5D x 0.75H	1
P14494-CR-14	200	200	CR200	6W x 3D x 1.5H	2
P14494-CR-15	150	200	CR200	6W x 3D x 1.5H	2
P14494-CR-16	100	200	CR200	6W x 3D x 1.5H	2
P14494-CR-18	50	200	CR200	6W x 3D x 1.5H	1
P14494-CR-20	200	300	CR300	9W x 3D x 1.5H	3
P14494-CR-21	150	300	CR300	9W x 3D x 1.5H	3
P14494-CR-22	100	300	CR300	9W x 3D x 1.5H	3
P14494-CR-24	50	300	CR300	9W x 3D x 1.5H	3
P14494-CR-26	40	300	CR300	9W x 3D x 1.5H	3
P14494-CR-29	150	400	CR400	12W x 3D x 1.5H	4
P14494-CR-30	100	400	CR400	12W x 3D x 1.5H	4
P14494-CR-32	50	400	CR400	12W x 3D x 1.5H	4
P14494-CR-33	45	400	CR400	12W x 3D x 1.5H	4
P14494-CR-34	40	400	CR400	12W x 3D x 1.5H	4
P14494-CR-38	23	500	CR500	15W x 3D x 1.5H	5
P14494-CR-40	50	500	CR500	15W x 3D x 1.5H	5
P14494-CR-41	45	500	CR500	15W x 3D x 1.5H	5
P14494-CR-54	18	300	CR300	9W x 3D x 1.5H	3
P14494-CR-55	18	400	CR400	12W x 3D x 1.5H	4
P14494-CR-56	18	500	CR500	15W x 3D x 1.5H	5
P14494-CR-57	100	500	CR500	15W x 3D x 1.5H	5

# Braking resistors

## Technical data

### Type CR Case Resistors

Wattage	Dimension (in)				
	A	B	C	D	E
100	6	1-1/2	3/4	5-1/2	3/4
150	9	1-1/2	3/4	8-1/2	3/4
200	6	3	1-1/2	5-1/2	1-1/2
300	9	3	1-1/2	8-1/2	1-1/2
400	12	3	1-1/2	11-1/2	1-1/2
500	15	3	1-1/2	14-1/2	1-1/2

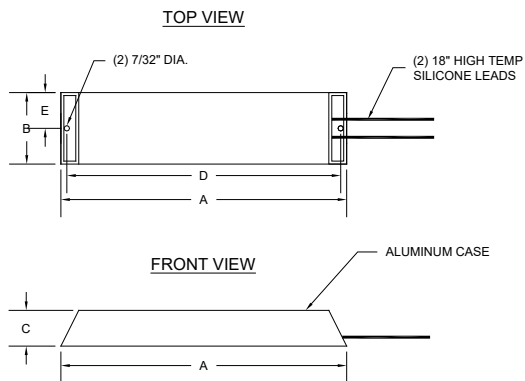

### Type GCE Enclosure Dimensions and Coil Options

Part No.	Max. No. WR Cols	Max No. SXR, VR or ER	Dimensions (in)				
			A	B	C	D	E
GCE1	1	(1) Size 2	12	5	5	10-1/2	---
GCE2	2	(2) Size 2	12	7	5	10-1/2	4-1/2
GCE3	3	(3) Size 2	12	10	5	10-1/2	7-1/2
GCE4	4	(4) Size 2	12	13	5	10-1/2	10-1/2
GCE5	5	(5) Size 2	12	16	5	10-1/2	13-1/2
GCE6	6	(3) Size 5	19	10	5	17-1/2	7-1/2
GCE8	8	(4) Size 5	19	13	5	17-1/2	10-1/2
GCE9	9	(3) Size 7	26-1/2	10	5	25	7-1/2
GCE12	12	(4) Size 7	26-1/2	13	5	25	10-1/2

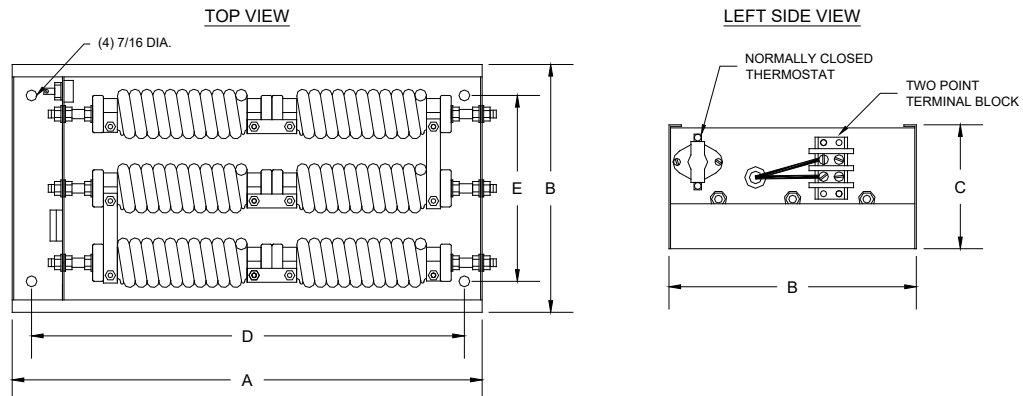

# Input reactors

## Applications

Line side power conditioning for AC motor controls to prevent unwanted harmonics and nuisance drive trips as well as to prevent excess current during line disturbances that can damage power semi-conductors. There should be a minimum impedance associated with the drive using either AC or DC magnetics. In many applications, this impedance can come from a supply transformer, or if long enough, the supply cable themselves. In most cases, however, the use of an additional input reactor is recommended.

## Features

UL Listed Open, UL Listed Type 1 and UL Listed Type 3R construction with connection terminals. 3% and 5% impedance rating at rated current. UL Listed reactors below 80A include lugs. Lugs are not included with reactor above 80A.

## Drive input current with and without input reactor

Type code	Frame Size	P <sub>HD</sub>	Input Rating*		Input with 5% reactor**	
			Hp		Hp	
			I <sub>IHD</sub> (230V)	I <sub>IHD</sub> (480V)	I <sub>IHD</sub> (230V)	I <sub>IHD</sub> (480V)
A	A	A	A			
<b>Single phase drive - 200-240V applications</b>						
ACS380-040x-02A4-1	R0	0.33	3.8	---	3.1	---
ACS380-040x-03A7-1	R0	0.5	5.0	---	4.2	---
ACS380-040x-04A8-1	R1	0.75	7.8	---	6.4	---
ACS380-040x-06A9-1	R1	1	10.1	---	8.3	---
ACS380-040x-07A8-1	R1	1.5	14.5	---	11.9	---
ACS380-040x-09A8-1	R2	2	16.4	---	13.5	---
ACS380-040x-12A2-1	R2	3	20.6	---	17.0	---
<b>Three phase drive - 200-240V applications</b>						
ACS380-040x-02A4-2	R1	0.33	2.7	---	1.8	---
ACS380-040x-03A7-2	R1	0.5	3.6	---	2.4	---
ACS380-040x-04A8-2	R1	0.75	5.6	---	3.7	---
ACS380-040x-06A9-2	R1	1	7.2	---	4.8	---
ACS380-040x-07A8-2	R1	1.5	10.4	---	6.9	---
ACS380-040x-09A8-2	R1	2	11.7	---	7.8	---
ACS380-040x-12A2-2	R2	3	14.7	---	9.8	---
ACS380-040x-17A5-2	R3	3	17.1	---	12.2	---
ACS380-040x-25A0-2	R3	5	24.6	---	18	---
ACS380-040x-032A-2	R3	7.5	34	---	25	---
ACS380-040x-048A-2	R4	10	36	---	32	---
ACS380-040x-055A-2	R4	15	52.3	---	48	---
<b>Three phase drive - 380-480V applications</b>						
ACS380-040x-01A8-4	R0	0.5	---	1.8	---	1.1
ACS380-040x-02A6-4	R1	0.75	---	2.6	---	1.6
ACS380-040x-03A3-4	R1	1	---	3.4	---	2.1
ACS380-040x-04A0-4	R1	1.5	---	4.8	---	3
ACS380-040x-05A6-4	R1	2	---	5.4	---	3.4
ACS380-040x-07A2-4	R1	2	---	6.4	---	4
ACS380-040x-09A4-4	R1	3	---	7.7	---	4.8
ACS380-040x-12A6-4	R2	5	---	12.2	---	7.6
ACS380-040x-17A0-4	R3	7.5	---	17.6	---	11
ACS380-040x-25A0-4	R3	10	---	22.4	---	14
ACS380-040x-032A-4	R4	15	---	29.5	---	21
ACS380-040x-038A-4	R4	20	---	35.5	---	27
ACS380-040x-045A-4	R4	25	---	42.3	---	34
ACS380-040x-050A-4	R4	30	---	48	---	40

\* Calculated. Assumes no system impedance.

\*\* Or equivalent system impedance

I<sub>IHD</sub> Input current at heavy duty output. Continuous rms input current (for dimensioning cables and fuses)

P<sub>HD</sub> Typical motor power in heavy-duty use (150% overload)

Consult Hardware Manual 3AXD50000029274 for more detailed information

# Input reactors - high impedance

## Input Reactors for Single Phase 200-240V applications (connect to terminals A and C)

Drive Part #	HP PN	Drive Input Current @ 230V	Drive Input Current @ 230V with 5% choke	Drive Output Current I <sub>2N</sub>	KDR 5%, UL Listed, Open				KDR 5%, UL Listed Type 1 Enclosure				KDR 5%, UL Listed Type 3R Enclosure			
					Part Number	Watts Loss	Dimensions (HxWxD)	Wt	Part Number	Watts Loss	Dimensions (HxWxD)	Wt	Part Number	Watts Loss	Dimensions (HxWxD)	Wt
02A4-1	0.25	3.8	3.1	1.8	KDRMA8L1	30.6	3.63x4.45x1.78	4	KDRMA8L1E01	30.6	12.3x12.5x6.75	12	KDRMA8L1E3R1	30.6	11.5x10x12	17
03A7-1	0.5	5	4.2	2.4	KDRMA8L1	30.6	3.63x4.45x1.78	4	KDRMA8L1E01	30.6	12.3x12.5x6.75	12	KDRMA8L1E3R1	30.6	11.5x10x12	17
04A8-1	0.75	7.8	6.4	3.7	KDRAA3L2	44.5	4.44x4.25x2.64	3	KDRAA3L2E01	44.5	12.3x12.5x6.75	13	KDRAA3L2E3R1	44.5	11.5x10x12	18
06A9-1	1	10.1	8.3	4.8	KDRAA28H2	42	4.44x4.25x2.64	3	KDRAA28H2E01	42	12.3x12.5x6.75	14	KDRAA28H2E3R1	42	11.5x10x12	18
07A8-1	1.5	14.5	11.9	6.9	KDRB25H	53.1	5.00x6.00x4.00	8	KDRB25HE01	53.1	12.25x12.5x6.75	18.5	KDRB25HE3R	53.1	11.5x10x12	23
09A8-1	2	16.4	13.5	7.8	KDRB25H	53.1	5.00x6.00x4.00	8	KDRB25HE01	53.1	12.25x12.5x6.75	18.5	KDRB25HE3R	53.1	11.5x10x12	23
12A2-1	3	20.6	17	9.8	KDRB25H	53.1	5.00x6.00x4.00	8	KDRB25HE01	53.1	12.25x12.5x6.75	18.5	KDRB25HE3R	53.1	11.5x10x12	23

## Input Reactors for Three Phase 200-240V applications

Drive Part #	HP PN	Drive Input Current @ 230V	Drive Input current @ 230V with 5% choke	Drive Output Current I <sub>2N</sub>	KDR 5%, UL Listed, Open				KDR 5%, UL Listed Type 1 Enclosure				KDR 5%, UL Listed Type 3R Enclosure			
					Part Number	Watts Loss	Dimensions (HxWxD)	Wt	Part Number	Watts Loss	Dimensions (HxWxD)	Wt	Part Number	Watts Loss	Dimensions (HxWxD)	Wt
02A4-2	0.33	2.9	1.8	1.8	KDRMA4L1	12.1	3.63x4.45x1.78	2	KDRMA4L1E01	12.1	12.3x12.5x6.75	12	KDRMA4L1E3R1	12	11.5x10x12	17
03A7-2	0.5	3.8	2.4	2.4	KDRMA6L1	26.4	3.63x4.45x1.78	4	KDRMA6L1E01	26.4	12.3x12.5x6.75	12	KDRMA6L1E3R1	12	11.5x10x12	17
04A8-2	0.75	5.9	3.7	3.7	KDRMA8L1	30.6	3.63x4.45x1.78	4	KDRMA8L1E01	30.6	12.3x12.5x6.75	12	KDRMA8L1E3R1	12	11.5x10x12	17
06A9-2	1	7.7	4.8	4.8	KDRAA6L2	39.2	4.44x4.25x2.64	3	KDRAA6L2E01	39.2	12.3x12.5x6.75	13	KDRAA6L2E3R1	13	11.5x10x12	18
07A8-2	1.5	11.0	6.9	6.9	KDRAA3L2	44.5	4.44x4.25x2.64	3	KDRAA3L2E01	44.5	12.3x12.5x6.75	13	KDRAA3L2E3R1	13	11.5x10x12	18
09A8-2	2	12.5	7.8	7.8	KDRAA28H2	42	4.44x4.25x2.64	3	KDRAA28H2E01	42	12.3x12.5x6.75	14	KDRAA28H2E3R1	42	11.5x10x12	18
12A2-2	2	15.7	9.8	9.8	KDRAA28H2	42	4.44x4.25x2.64	3	KDRAA28H2E01	42	12.3x12.5x6.75	14	KDRAA28H2E3R1	42	11.5x10x12	18
17A5-2	3	19.5	12.2	12.2	KDRB25H	53.1	5.00x6.00x4.00	8	KDRB25HE01	53.1	12.25x12.5x6.75	53.1	KDRB25HE3R	53.1	11.5x10x12	23
25A0-2	5	28	17.5	17.5	KDRB26H	66.5	5.00x6.00x4.00	8	KDRB26HE01	66.5	12.25x12.5x6.75	66.5	KDRB26HE3R	66.5	11.5x10x12	23
032A-2	7.5	40	25	25	KDRB26H	66.5	5.00x6.00x4.00	8	KDRB26HE01	66.5	12.25x12.5x6.75	66.5	KDRB26HE3R	66.5	11.5x10x12	23
048A-2	10	51.2	32	32	KDRD22H	107.8	5.75x7.20x4.25	12	KDRD22HE01	107.8	12.25x12.5x6.75	108	KDRD22HE3R	107.8	11.5x10x12	30
055A-2	15	76.8	48	48	KDRC22H	113.1	5.75x7.20x5.00	15	KDRC22HE01	113.1	12.25x12.5x6.75	113	KDRC22HE3R	113.1	11.5x10x12	33

## Input Reactors for Three Phase 380-480V applications

Drive Part #	HP PN	Drive Input Current @ 480V	Drive Input current @ 480V with 5% choke	Drive Output Current I <sub>2N</sub>	KDR 5%, UL Listed, Open				KDR 5%, UL Listed Type 1 Enclosure				KDR 5%, UL Listed Type 3R Enclosure			
					Part Number	Watts Loss	Dimensions (HxWxD)	Wt	Part Number	Watts Loss	Dimensions (HxWxD)	Wt	Part Number	Watts Loss	Dimensions (HxWxD)	Wt
01A8-4	0.5	1.8	1.1	1.1	KDRMA3H1	14.3	3.63x4.45x1.78	2	KDRMA3H1E01	14.3	12.3x12.5x6.75	12	KDRMA3H1E3R1	14.3	11.5x10x12	17
02A6-4	0.75	2.6	1.6	1.6	KDRMA4H1	19.3	3.63x4.45x1.78	2	KDRMA4H1E01	19.3	12.3x12.5x6.75	12	KDRMA4H1E3R1	19.3	11.5x10x12	17
03A3-4	1	3.4	2.1	2.1	KDRMA5H1	26.7	3.63x4.45x1.78	2	KDRMA5H1E01	26.7	12.3x12.5x6.75	12	KDRMA5H1E3R1	26.7	11.5x10x12	17
04A0-4	1.5	4.8	3.0	3.0	KDRMA6H1	30	3.63x4.45x1.78	2	KDRMA6H1E01	30	12.3x12.5x6.75	12	KDRMA6H1E3R1	30	11.5x10x12	17
05A6-4	2	5.4	3.4	3.4	KDRAA1H2	45	4.44x4.25x2.64	3	KDRAA1H2E01	45	12.3x12.5x6.75	13	KDRAA1H2E3R1	45	11.5x10x12	18
07A2-4	2	6.4	4.0	4.0	KDRAA2H2	41.8	4.44x4.25x2.64	3	KDRAA2H2E01	41.8	12.3x12.5x6.75	13	KDRAA2H2E3R1	41.8	11.5x10x12	18
09A4-4	3	7.7	4.8	4.8	KDRAA2H2	41.8	4.44x4.25x2.64	3	KDRAA2H2E01	41.8	12.3x12.5x6.75	13	KDRAA2H2E3R1	41.8	11.5x10x12	18
12A6-4	5	12	7.6	7.6	KDRAA3H2	66	4.44x4.25x2.64	4	KDRAA3H2E01	66	12.3x12.5x6.75	14	KDRAA3H2E3R1	66	11.5x10x12	19
17A0-4	7.5	18	11.0	11	KDRAA4H2	70	4.44x4.25x2.64	4	KDRAA4H2E01	70	12.25x12.5x6.75	14	KDRAA4H2E3R1	70	11.5x10x12	19
25A0-4	10	22	14	14	KDRAA5H2	98	4.44x4.25x2.64	4	KDRAA5H2E01	98	12.3x12.5x6.75	14	KDRAA5H2E3R1	98	11.5x10x12	19
032A-4	15	34	21	21	KDRB2H	133	5.00x6.00x4.00	7	KDRB2HE01	133	12.25x12.5x6.75	17.5	KDRB2HE3R	133	11.5x10x12	22
038A-4	20	43	27	27	KDRC3H	108	5.00x6.00x4.00	7	KDRC3HE01	108	12.25x12.5x6.75	17.5	KDRC3HE3R	108	11.5x10x12	22
045A-4	25	54	34	34	KDRC1H	112	5.75x7.20x5.00	15	KDRC1HE01	112	12.25x12.5x6.75	25.5	KDRC1HE3R	112	11.5x10x12	30
050A-4	30	64	40	40	KDRE2H	141	5.75x7.20x5.00	16	KDRE2HE01	141	12.25x12.5x6.75	26.5	KDRE2HE3R	141	11.5x10x12	31

All KDR resistors in sizes that match with ACS380 drives include lugs, no separate lug kits are required  
Wt - weight

# Input reactors - low impedance

## Input Reactors for Single Phase 200-240V applications (connect to terminals A and C)

Drive Part #	HP	Drive Input Current** @ 230V	Drive Input current @ 230V with 3% choke	Drive Output Current $I_{2N}$	KDR 3%, UL Listed, Open				KDR 3%, UL Listed Type 1 Enclosure				KDR 3%, UL Listed Type 3R Enclosure			
					Part Number	Watts Loss	Dimensions (HxWxD)	Wt	Part Number	Watts Loss	Dimensions (HxWxD)	Wt	Part Number	Watts Loss	Dimensions (HxWxD)	Wt
02A4-1	0.25	3.8	3.1	1.8	KDRAA3L2	44.5	4.44x4.25x2.64	3	KDRAA3L2E01	44.5	12.25x12.5x6.75	13.4	KDRAA3L2E3R1	44.5	11.5x10x12	18
03A7-1	0.5	5	4.2	2.4	KDRAA4L2	62.9	4.44x4.25x2.64	3	KDRAA4L2E01	63	12.25x12.5x6.75	13.4	KDRAA4L2E3R1	62.9	11.5x10x12	19
04A8-1	0.75	7.8	6.4	3.7	KDRAA4L2	62.9	4.44x4.25x2.64	3	KDRAA4L2E01	63	12.25x12.5x6.75	13.4	KDRAA4L2E3R1	62.9	11.5x10x12	19
06A9-1	1	10.1	8.3	4.8	KDRMA27L1	27	3.63x4.45x1.78	2	KDRMA27L1E01	27	12.25x12.5x6.75	12	KDRMA27L1E3R1	27	11.5x10x12	17
07A8-1	1.5	14.5	11.9	6.9	KDRAA28L2	42	4.44x4.25x2.64	3	KDRAA28L2E01	42	12.25x12.5x6.75	14	KDRAA28L2E3R1	42	11.5x10x12	18
09A8-1	2	16.4	13.5	7.8	KDRB22L	38	5.00x6.00x4.00	8	KDRB22LE01	38	12.25x12.5x6.75	18.5	KDRB22LE3R	38	11.5x10x12	23
12A2-1	3	20.6	17	9.8	KDRB22L	38	5.00x6.00x4.00	8	KDRB22LE01	38	12.25x12.5x6.75	18.5	KDRB22LE3R	38	11.5x10x12	23

## Input Reactors for Three Phase 200-240V applications

Drive Part #	HP	Drive Input Current** @ 230V	Drive Input current @ 230V with 3% choke	Drive Output Current $I_{2N}$	KDR 3%, UL Listed, Open				KDR 3%, UL Listed Type 1 Enclosure				KDR 3%, UL Listed Type 3R Enclosure			
					Part Number	Watts Loss	Dimensions (HxWxD)	Wt	Part Number	Watts Loss	Dimensions (HxWxD)	Wt	Part Number	Watts Loss	Dimensions (HxWxD)	Wt
02A4-2	0.33	2.9	1.8	1.8	KDRMA8L1	30.6	3.36x4.45x1.78	4	KDRMA8L1E01	30.6	12.25x12.5x6.75	12	KDRMA8L1E3R1	30.6	11.5x10x12	17
03A7-2	0.5	3.8	2.4	2.4	KDRMA8L1	30.6	3.36x4.45x1.78	4	KDRMA8L1E01	30.6	12.25x12.5x6.75	12	KDRMA8L1E3R1	30.6	11.5x10x12	17
04A8-2	0.75	5.9	3.7	3.7	KDRAA4L2	62.9	4.44x4.25x2.64	3	KDRAA4L2E01	62.9	12.25x12.5x6.75	14	KDRAA4L2E3R1	62.9	11.5x10x12	18
06A9-2	1	7.7	4.8	4.8	KDRAA4L2	62.9	4.44x4.25x3.53	4	KDRAA4L2E01	62.9	12.25x12.5x6.75	14	KDRAA4L2E3R1	62.9	11.5x10x12	18
07A8-2	1.5	11.0	6.9	6.9	KDRAA4L2	62.9	4.44x4.25x3.53	4	KDRAA4L2E01	62.9	12.25x12.5x6.75	14	KDRAA4L2E3R1	62.9	11.5x10x12	18
09A8-2	2	12.5	7.8	7.8	KDRMA27L1	27	3.63x4.45x1.78	2	KDRMA27L1E01	27	12.25x12.5x6.75	12	KDRMA27L1E3R1	27	11.5x10x12	17
12A2-2	2	15.7	9.8	9.8	KDRMA27L1	27	3.63x4.25x1.78	2	KDRMA27L1E01	27	12.25x12.5x6.75	12	KDRMA27L1E3R1	27	11.5x10x12	17
17A5-2	3	19.5	12.2	12.2	KDRB22L	38	5.00x6.00x4.00	8	KDRB22LE01	38	12.25x12.5x6.75	18.5	KDRB22LE3R	38	11.5x10x12	23
25A0-2	5	28	17.5	17.5	KDRB22L	38	5.00x6.00x4.00	8	KDRB22LE01	38	12.25x12.5x6.75	18.5	KDRB22LE3R	38	11.5x10x12	23
032A-2	7.5	40	25	25	KDRB23L	48	5.00x6.00x4.00	8	KDRB23LE01	48	12.25x12.5x6.75	18.5	KDRB23LE3R	48	11.5x10x12	23
048A-2	10	51.2	32	32	KDRD25L	64	5.75x7.2x4.25	12	KDRD25LE01	64	12.25x12.5x6.75	22.5	KDRD25LE3R	64	11.5x10x12	27
055A-2	15	76.8	48	48	KDRD24L	85	5.75x7.2x4.25	12	KDRD24LE01	85	12.25x12.5x6.75	22.5	KDRD24LE3R	85	11.5x10x12	27

## Input Reactors for Three Phase 380-480V applications

Drive Part #	HP	Drive Input Current** @ 480V	Drive Input current @ 480V with 3% choke	Drive Output Current $I_{2N}$	KDR 3%, UL Listed, Open				KDR 3%, UL Listed Type 1 Enclosure				KDR 3%, UL Listed Type 3R Enclosure			
					Part Number	Watts Loss	Dimensions (HxWxD)	Wt	Part Number	Watts Loss	Dimensions (HxWxD)	Wt	Part Number	Watts Loss	Dimensions (HxWxD)	Wt
01A8-4	0.5	1.8	1.1	1.1	KDRMA3L1	9.7	3.63x4.45x1.78	2	KDRMA3L1E01	9.7	12.25x12.5x6.75	12	KDRMA3L1E3R1	9.7	11.5x10x12	17
02A6-4	0.75	2.6	1.6	1.6	KDRMA4L1	12.1	3.63x4.45x1.78	2	KDRMA4L1E01	12.1	12.25x12.5x6.75	12	KDRMA4L1E3R1	12.1	11.5x10x12	17
03A3-4	1	3.4	2.1	2.1	KDRMA5L1	25.2	3.63x4.45x1.78	2	KDRMA5L1E01	25.2	12.25x12.5x6.75	12	KDRMA5L1E3R1	25.2	11.5x10x12	17
04A0-4	1.5	4.8	3.0	3.0	KDRMA6L1	26.4	3.63x4.45x1.78	2	KDRMA6L1E01	26.4	12.25x12.5x6.75	12	KDRMA6L1E3R1	26.4	11.5x10x12	17
05A6-4	2	5.4	3.4	3.4	KDRMA7L1	23.5	3.63x4.45x1.78	2	KDRMA7L1E01	23.5	12.25x12.5x6.75	12	KDRMA7L1E3R1	23.5	11.5x10x12	17
07A2-4	2	6.4	4.0	4.0	KDRMA8L1	30.6	3.63x4.45x1.78	2	KDRMA8L1E01	30.6	12.25x12.5x6.75	12	KDRMA8L1E3R1	30.6	11.5x10x12	17
09A4-4	3	7.7	4.8	4.8	KDRMA8L1	30.6	3.63x4.45x1.78	2	KDRMA8L1E01	30.6	12.25x12.5x6.75	12	KDRMA8L1E3R1	30.6	11.5x10x12	17
12A6-4	5	12	7.6	7.6	KDRAA3L2	48.8	4.44x4.25x2.64	3	KDRAA3L2E01	48.8	12.25x12.5x6.75	14	KDRAA3L2E3R1	48.8	11.5x10x12	18
17A0-4	7.5	18	11.0	11	KDRAA4L2	62.9	4.44x4.25x2.64	4	KDRAA4L2E01	62.9	12.25x12.5x6.75	14	KDRAA4L2E3R1	62.9	11.5x10x12	18
25A0-4	10	22	14	14	KDRAA5L2	77	4.44x4.25x2.64	4	KDRAA5L2E01	77	12.25x12.5x6.75	14	KDRAA5L2E3R1	77	11.5x10x12	18
032A-4	15	34	21	21	KDRB2L	65	5.00x6.00x4.00	8	KDRB2LE01	65	12.25x12.5x6.75	18.5	KDRB2LE3R	65	11.5x10x12	19
038A-4	20	43	27	27	KDRB2L	65	5.00x6.00x4.00	8	KDRB2LE01	65	12.25x12.5x6.75	18.5	KDRB2LE3R	65	11.5x10x12	19
045A-4	25	54	34	34	KDRD1L	96	5.75x7.2x4.25	10	KDRD1LE01	96	12.25x12.5x6.75	20.5	KDRD1LE3R	96	11.5x10x12	25
050A-4	30	64	40	40	KDRD1L	96	5.75x7.2x4.25	10	KDRD1LE01	96	12.25x12.5x6.75	20.5	KDRD1LE3R	96	11.5x10x12	25

All KDR resistors in sizes that match with ACS380 drives include lugs, no separate lug kits are required

Wt - weight

# dv/dt output filters

## Applications

V1k Output Filters provide motor protection by limiting voltage spikes to 1,000 volts, or below, for long motor cable applications. Greatly extends the life of the motor and cable for all applications up to 1000 feet. For multi-motor applications note that motor lead length is cumulative and the 1000 foot limit still applies. 30% reduction in common mode current.

## Features

UL Listed Open, UL Listed Type 1 and UL Listed Type 3R construction with connection terminals.

**Note:** The drives internal EMC filter must remain disconnected when using these filters. When applying these output filters the drive output frequency is limited to 60Hz.

### Output Filters for Single Phase 200-240V applications

Drive Part No.	HP	Output Current	V1K UL Open				V1K UL Type 1 Enclosure				V1k UL Type 3R Enclosure			
			Part Number	Watts Loss	Dimensions (HxWxD)	Weight	Part Number	Watts Loss	Dimensions (HxWxD)	Weight	Part Number	Watts Loss	Dimensions (HxWxD)	Weight
ACS380-040x-	ND													
02A4-1	0.5	1.8	V1K2A00	75	9x5.50x7.25	8	V1K2A01	75	9x5.50x10	11	V1K2A03	11	11.45x10x12	25
03A7-1	0.75	2.4	V1K3A00	75	9x5.50x7.25	8	V1K3A01	75	9x5.50x10	11	V1K3A03	75	11.45x10x12	25
04A8-1	1	3.7	V1K4A00	75	9x5.50x7.25	8	V1K4A01	75	9x5.50x10	11	V1K4A03	75	11.45x10x12	25
06A9-1	1.5	4.8	V1K6A00	80	9x5.50x7.25	8	V1K6A01	80	9x5.50x10	11	V1K6A03	80	11.45x10x12	25
07A8-1	2	6.9	V1K8A00	90	9x5.50x7.25	8	V1K8A01	90	9x5.50x10	11	V1K8A03	90	11.45x10x12	25
09A8-1	3	7.8	V1K8A00	90	9x5.50x7.25	8	V1K8A01	90	9x5.50x10	11	V1K8A03	90	11.45x10x12	25
12A2-1	3	9.8	V1K12A00	95	9x5.50x7.25	8	V1K12A01	95	9x5.50x10	11	V1K12A03	95	11.45x10x12	25

### Output Filters for Three Phase 200-240V applications

Drive Part No.	HP	Output Current	V1K UL Open				V1K UL Type 1				V1k UL Type 3R			
			Part Number	Watts Loss	Dimensions (HxWxD)	Weight	Part Number	Watts Loss	Dimensions (HxWxD)	Weight	Part Number	Watts Loss	Dimensions (HxWxD)	Weight
ACS380-040x-	ND													
02A4-2	0.33	1.8	V1K2A00	75	9x5.50x7.25	8	V1K2A01	75	9x5.50x10	11	V1K2A03	11	11.45x10x12	25
03A7-2	0.5	2.4	V1K3A00	75	9x5.50x7.25	8	V1K3A01	75	9x5.50x10	11	V1K3A03	75	11.45x10x12	25
04A8-2	0.75	3.7	V1K4A00	75	9x5.50x7.25	8	V1K4A01	75	9x5.50x10	11	V1K4A03	75	11.45x10x12	25
06A9-2	1	4.8	V1K6A00	80	9x5.50x7.25	8	V1K6A01	80	9x5.50x10	11	V1K6A03	80	11.45x10x12	25
07A8-2	1.5	6.9	V1K8A00	90	9x5.50x7.25	8	V1K8A01	90	9x5.50x10	11	V1K8A03	90	11.45x10x12	25
09A8-2	2	7.8	V1K8A00	90	9x5.50x7.25	8	V1K8A01	90	9x5.50x10	11	V1K8A03	90	11.45x10x12	25
12A2-2	2	9.8	V1K12A00	95	9x5.50x7.25	8	V1K12A01	95	9x5.50x10	11	V1K12A03	95	11.45x10x12	25
17A5-2	3	12.2	V1K16A00	95	9x5.50x8.25	12	V1K16A01	95	9x5.50x10	15	V1K16A03	15	11.45x10x12	29
25A0-2	5	17.5	V1K18A00	110	9x5.50x8.25	12	V1K18A01	110	9x5.50x10	15	V1K18A03	110	11.45x10x12	25
032A-2	7.5	25	V1K25A00	110	9x5.50x8.25	12	V1K25A01	110	9x5.50x10	15	V1K25A03	110	11.45x10x12	29
048A-2	10	32	V1K35A00	130	12x8x9	17	V1K35A01	130	12x8x11.50	23	V1K35A03	130	19.18x15.62x19.50	56
055A-2	15	48	V1K55A00	145	12x8x9	23	V1K55A01	145	12x8x11.50	23	V1K55A03	145	19.18x15.62x19.50	56

### Output Filters for Three Phase 380-480V applications

Drive Part No.	HP	Output Current	V1K UL Open				V1K UL Type 1				V1k UL Type 3R			
			Part Number	Watts Loss	Dimensions (HxWxD)	Weight	Part Number	Watts Loss	Dimensions (HxWxD)	Weight	Part Number	Watts Loss	Dimensions (HxWxD)	Weight
ACS380-040x-	ND													
01A8-4	0.5	1.1	V1K2A00	75	9x5.50x7.25	8	V1K2A01	75	9x5.50x10	11	V1K2A03	11	11.45x10x12	25
02A6-4	0.75	1.6	V1K2A00	75	9x5.50x7.25	8	V1K2A01	75	9x5.50x10	11	V1K2A03	11	11.45x10x12	25
03A3-4	1	2.1	V1K3A00	75	9x5.50x7.25	8	V1K3A01	75	9x5.50x10	11	V1K3A03	75	11.45x10x12	25
04A0-4	1.5	3	V1K3A00	75	9x5.50x7.25	8	V1K3A01	75	9x5.50x10	11	V1K3A03	75	11.45x10x12	25
05A6-4	2	3.4	V1K4A00	75	9x5.50x7.25	8	V1K4A01	75	9x5.50x10	11	V1K4A03	75	11.45x10x12	25
07A2-4	2	4	V1K4A00	75	9x5.50x7.25	8	V1K4A01	75	9x5.50x10	11	V1K4A03	75	11.45x10x12	25
09A4-4	3	4.8	V1K6A00	80	9x5.50x7.25	8	V1K6A01	80	9x5.50x10	11	V1K6A03	80	11.45x10x12	25
12A6-4	5	7.6	V1K8A00	90	9x5.50x7.25	8	V1K8A01	90	9x5.50x10	11	V1K8A03	90	11.45x10x12	25
17A0-4	7.5	11	V1K12A00	95	9x5.50x7.25	8	V1K12A01	95	9x5.50x10	11	V1K12A03	95	11.45x10x12	25
25A0-4	10	14	V1K16A00	95	9x5.50x8.25	12	V1K16A01	95	9x5.50x10	15	V1K16A03	15	11.45x10x12	29
032A-4	15	21	V1K21A00	110	9x5.50x8.25	12	V1K21A01	110	9x5.50x10	15	V1K21A03	110	11.45x10x12	29
038A-4	20	27	V1K27A00	110	9x5.50x8.25	14	V1K27A01	110	9x5.50x10	15	V1K27A03	110	19.18x15.62x19.50	59
045A-4	25	34	V1K35A00	130	12x8x9	17	V1K35A01	130	12x8x11.50	23	V1K35A03	130	19.18x15.62x19.50	56
050A-4	30	40	V1K45A00	135	12x8x9	17	V1K45A01	135	12x8x11.50	23	V1K45A03	135	19.18x15.62x19.50	56

# Need a motor? This is our offering.

Our machinery drives control virtually any type of AC motor including induction, permanent magnet, servo and synchronous reluctance motors. Our adaptable machinery drives ensure an energy efficient and reliable motor controller with significant cost savings for the user.

## **Machinery drives and induction motors form a reliable combination**

Induction motors are used throughout the industry in several types of industry applications which demand robust and high enclosure motor and drive solutions. The ACS380 machinery drives fit perfectly together with this type of motor, used in a wide range of industrial environments.

## **Machinery drives and permanent magnet motors for smooth operation**

Permanent magnet technology is often used for

improved motor characteristics such as energy efficiency, compactness and control performance. Actual characteristics between different permanent magnet motors can vary considerably. Machinery drives can control ABB's and most other permanent magnet motors in an efficient way.

## **Machinery drives and IE4 synchronous reluctance motors for a package with high efficiency**

Combining the machinery drives control technology with our synchronous reluctance (SynRM) motors provides an IE4 motor and drive package that gives you great energy savings benefits. The key is in the rotor design. The synchronous reluctance rotor replaces the traditional induction rotor and requires no permanent magnets. ABB has tested the SynRM motor and drive packages and produced manufacturer's statements providing verified system (drive and motor efficiency).

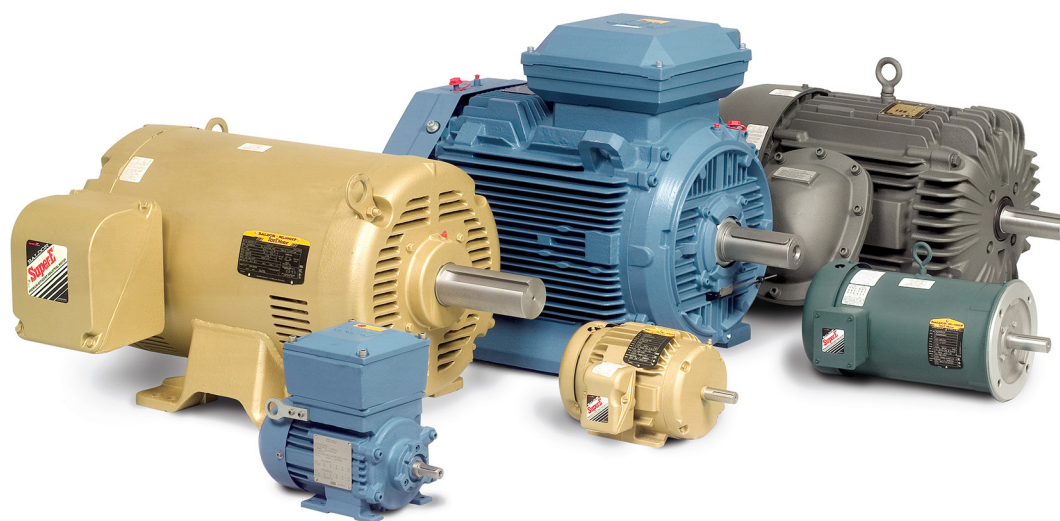

# Save time, ease troubleshooting and improve drive performance with ABB smartphone apps

## Better connectivity and user experience with Drivetune

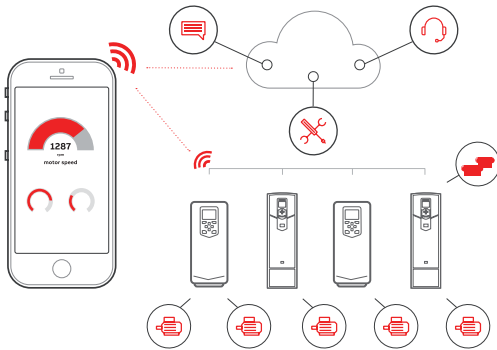

Easy and fast access to product information and support

## Manage your drives and the process lines and machines they control



Easy access to cloud-based drive and process information from anywhere via an online connection



Start up, commission and tune your drive and application



Simplified user guidance with instant access to drive status and configuration



Performance optimization via drive troubleshooting features and fast support

## Services and support on the go with Drivebase

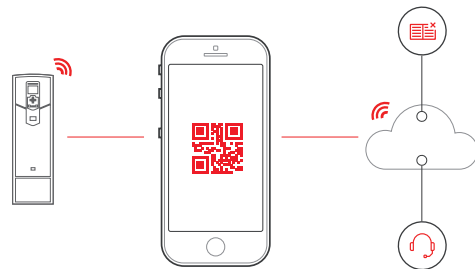

Search for support documents and contacts

## Maintain and service all your installed drives on one or multiple sites



Get 6 months extra warranty for free by registering your drive with the Drivebase app



Access your product and service information in the cloud from anywhere



Access your drive's diagnostics data



Push notifications for critical product and service updates

## Access information anywhere

Download the apps using the QR codes below or directly from the app stores



**Drivetune** for commissioning and managing drives

**Drivebase** for ensured reliability and reduced downtime on production sites

# A lifetime of peak performance

You're in control of every phase of the life of your drive. At the heart of drive services is a four-phase product life cycle management model. This model defines the services recommended and available throughout your drive's lifespan.

Now it's easy for you to see the exact service and maintenance available for your drives.

## ABB drives life cycle phases explained:



Full range of life cycle services and support

Limited range of life cycle services and support

Replacement and end-of-life services

	Active	Classic	Limited	Obsolete
Product	Product is in active sales and manufacturing phase.	Serial production has ceased. Product may be available for plant extensions, as a spare part or for installed base renewal.	Product is no longer available.	Product is no longer available.
Services	Full range of life cycle services is available.	Full range of life cycle services is available. Product enhancements may be available through upgrade and retrofit solutions.	Limited range of life cycle services is available. Spare parts availability is limited to available stock.	Replacement and end-of-life services are available.

### Keeping you informed

We notify you every step of the way using life cycle status statements and announcements.

The benefit for you is clear information about the status of your drives and the exact services available. It helps you plan the preferred service actions ahead of time and make sure that continuous support is always available.

### Step 1

#### Life Cycle Status Announcement

Provides early information about the upcoming life cycle phase change and how it affects the availability of services.

### Step 2

#### Life Cycle Status Statement

Provides information about the drive's current life cycle status, the availability of product and services, the life cycle plan, and recommended actions.

# Services to match your needs

Your service needs depend on your operation, life cycle of your equipment and business priorities. We have identified our customers' four most common needs and defined service options to satisfy them. What is your choice to keep your drives at peak performance?

## Is uptime your priority?

Keep your drives running with precisely planned and executed maintenance.

### Example services include:

- ABB Ability Life Cycle Assessment
- Installation and Commissioning
- Spare Parts
- Preventive Maintenance
- Reconditioning
- ABB Drive Care agreement
- Drive Exchange

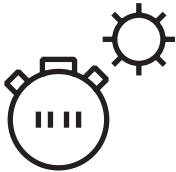

Operational efficiency

## Is rapid response a key consideration?

If your drives require immediate action, our global network is at your service.

### Example services include:

- Technical Support
- On-site Repair
- ABB Ability Remote Assistance
- Response time agreements
- Training



Rapid response

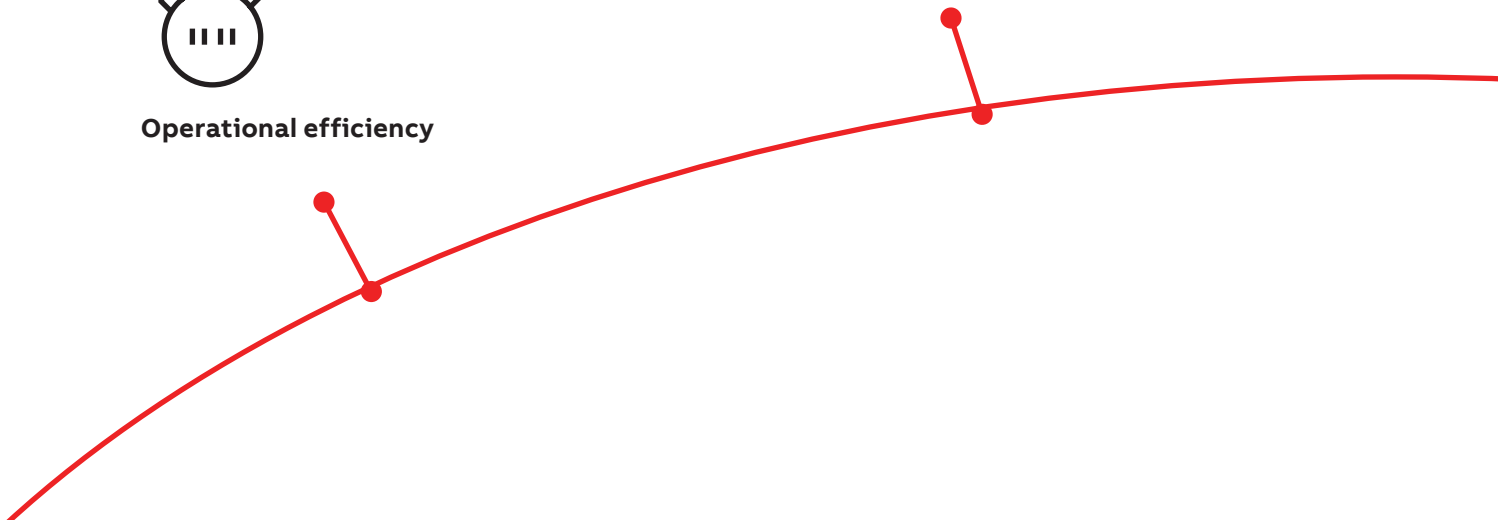

# Drives service

## Your choice, your future

### The future of your drives depends on the service you choose.

Whatever you choose, it should be a well-informed decision. No guesswork. We have the expertise and experience to help you find and implement the right service for your drive equipment. You can start by asking yourself these two critical questions:

- Why should my drive be serviced?
- What would my optimal service options be?

From here, you have our guidance and full support along the course you take, throughout the entire lifetime of your drives.

### Need to extend your assets' lifetime?

Maximize your drive's lifetime with our services.

#### Example services include:

- ABB Ability Life Cycle Assessment
- Upgrades, Retrofits and Modernization
- Replacement, Disposal and Recycling



Life cycle management

### Your choice, your business efficiency

ABB Drive Care agreement lets you focus on your core business. A selection of predefined service options matching your needs provides optimal, more reliable performance, extended drive lifetime and improved cost control. So you can reduce the risk of unplanned downtime and find it easier to budget for maintenance.

### We can help you more by knowing where you are!

Register your drive at [www.abb.com/drivereg](http://www.abb.com/drivereg) for extended warranty options and other benefits.

### Is performance most critical to your operation?

Get optimal performance out of your machinery and systems.

#### Example services include:

- ABB Ability Remote Services
- Engineering and Consulting
- Inspection and Diagnostics
- Upgrades, Retrofits and Modernization
- Workshop Repair
- Tailored services



Performance improvement





—  
For more information, please contact  
your local ABB representative or visit

**[www.abb.com/drives](http://www.abb.com/drives)**  
**[www.abb.com/drivespartners](http://www.abb.com/drivespartners)**  
**[www.abb.com/motors&generators](http://www.abb.com/motors&generators)**

Online manuals  
for the ACS380 drives



Video playlist:  
ACS380 how-to videos

